



FCTUC DEPARTAMENTO DE ENGENHARIA CIVIL
FACULDADE DE CIÊNCIAS E TECNOLOGIA
UNIVERSIDADE DE COIMBRA

Study of splice bolted connections in truss steel structures with hollow sections

Dissertation submitted for the degree of Master of Civil Engineering Expertise in Structural Mechanics

Author

João Diogo da Fonseca Silva

Supervisors

Rui António Duarte Simões

This dissertation is the sole responsibility of this author, not having suffered corrections after the public thesis presentation. The Department of Civil Engineering FCTUC accepts no responsibility for the use of the presented information.

Coimbra, July, 2014

ACKNOWLEDGMENT

Firstly I would like to thank Professor Doctor Rui António Duarte Simões for all the guidance, motivation and help. A personal note of thanks to Professor Doctor Sandra Filomena Silva Jordão for all the advices and work revision.

To Grupo Ferpinta and Engineer Bruno Marques, for the materials and specimen production.

To all the lab technicians that gave their time to help me complete the tests.

To my family for all the unconditional support they offered me. My mother Leonilde, my father Delfim, my brother Bruno, my grandmother Ilda and grandfather Francisco.

To the city of Coimbra for providing me with the life experience that made me the person I am today.

To my friends and colleagues.

ABSTRACT

When developing a metal structure project it's necessary to correctly comprehend and analyze the connections influence in the structure. These are key points in the effort transmission and therefore heavily conditioning the structures behavior.

Given any structures dimension, this are segmented in modules in order to enable an easier and more economic transportation, being assembled afterwards in the desired location. To execute the joints between this modules, it's often used welded or bolted splice connections. Due to the difficulty of execution in construction site and ensuring the joint's quality, the welded solution is lastly chosen giving primacy to bolted connections that are simpler and less expensive to execute in site.

The present work aims to increase the existing knowledge in the field of bolted connections, through the study of a splice connection between circular hollow sections. The connection is submitted to pure tension efforts, typical in trussed structures.

The connection presents itself as the connection of two hollow sections using short segments of thicker tubes fitted with inner plates responsible for the effort transfer. This elements are connected through bolts submitted with shear stresses with two distinct typologies, both of them dissimulated giving the connection a plane appearance.

The connection's study is carried through experimental program and numerical modeling using the finite element method. The obtained results are then confronted with the existing European norms.

RESUMO

No desenvolvimento de um projeto de estruturas metálicas é necessário compreender e analisar corretamente a influência que as ligações têm na estrutura. Estas constituem pontos fulcrais na transmissão dos esforços e como tal, condicionam fortemente o comportamento da estrutura.

Dada a dimensão das estruturas, estas são seccionadas em módulos de modo a possibilitar um transporte facilitado e económico sendo posteriormente montadas no local pretendido. A junção destes módulos é frequentemente executada através de ligações de emenda, soldadas ou aparafusadas. Sendo mais difícil a execução e garantia de qualidade de ligações soldadas em obra, estas são preteridas para ligações mais simples de executar *in situ* e consequentemente mais económicas, ou seja, ligações aparafusadas.

O presente trabalho pretende acrescentar conhecimento ao campo das ligações aparafusadas através do estudo de uma ligação de emenda entre perfis tubulares. Como tal, a ligação será submetida a esforço de tração puro, situação comum em estruturas treliçadas.

A ligação consiste na junção de dois perfis tubulares por intermédio de pequenos troços de tubos de elevada espessura munidos de chapas interiores que farão a transferência de esforços. Estes elementos são unidos através de parafusos a trabalhar ao corte com duas tipologias distintas, ambas embutidas no tubo exterior, conferindo à ligação um aspeto dissimulado e impercetível.

O estudo da ligação é efetuado com recurso a um programa experimental e modelação numérica através de elementos finitos. Os resultados obtidos são confrontados com as normas Europeias para ligações sujeitas a corte.

CONTENTS

1	INTRODUCTION	1
1.1	Framing	1
1.2	Metal structures of hollow circular sections	1
1.2.1	Context and application	1
1.2.2	Hollow circular section.....	3
1.3	Objective	4
1.4	Thesis structure	6
2	STATE OF THE ART	7
2.1	Historic evolution	7
2.2	Normative documents, research and publications	8
2.3	Existing splice connections between hollow sections	14
2.3.1	Introduction	14
2.3.2	Bolts.....	16
2.3.3	Flange-plate Joint	17
2.3.4	Lateral plate connection.....	19
2.3.5	Friction joint with high resistance bolts	19
2.3.6	Nailed connection	20
3	EXPERIMENTAL PROCEDURE.....	22
3.1	Introduction.....	22
3.2	Specimens definition.....	24
3.2.1	Geometry	24
3.2.2	Mechanical properties of the material	26
3.3	Instrumentation	27
3.4	Experimental setup and test protocol.....	29
3.5	Results analysis	30
3.5.1	Introduction	30
3.5.2	Failure modes	30
3.5.3	Tension-displacement curves	32
3.5.4	Extensometers data	36
4	NUMERIC PROCEDURE.....	39

4.1	Introduction.....	39
4.2	Geometry	39
4.3	Support and load conditions	41
4.4	Element	41
4.5	Material properties	44
4.6	Interaction and contact.....	45
4.7	Results analysis and comparison	46
5	ANALITIC PROCEDURE	53
5.1	Introduction.....	53
5.2	Bolted connection shear behavior.....	53
5.3	Formulation predicted in Eurocode 3, Part 1-8 for bearing connections.....	54
5.4	Results and comparison with previous methods.....	56
6	CONCLUSIONS AND FUTURE DEVELOPMENTS	58
6.1	Conclusions.....	58
6.2	Future developments.....	58
7	REFERENCES	60

1 INTRODUCTION

1.1 Framing

Over the last decades it has been possible to witness a noticeable growth in the use of steel in construction. In many architectural works of art, prominent technological advancements and engineering noteworthy works have a tight, or even, a full association with steel, characterizing this material as an avant-garde solution and a synonymous of advancement. Its physical and chemical properties allowed a transformation in building methodologies, enabling a pre-execution phase capable of hastening the execution time by requiring only an onsite assemble, elevating the quality and efficiency of the overall project. Considering also the recent changes in social behavior regarding the mass production and consumption, resulting in a positive ecofriendly conscience, the concept of durability and sustainability in construction as grown a more profound impact, in this context steel is a highly interesting material due to the fact that it is fully recyclable.

1.2 Metal structures of hollow circular sections

1.2.1 Context and application

For different structural problems there are different solutions, the choice of the cross section is a decision for the structural designer and he should aim to answer structural, aesthetics and efficiency issues.

The hollow sections, or tubes, have an excellent behavior to bending, torsion and axial efforts that combined with an appealing clean line, provides a solution that satisfies both engineers and architects. This characteristics ensure an increasing use of hollow sections that can be verified in Figure 1.1.

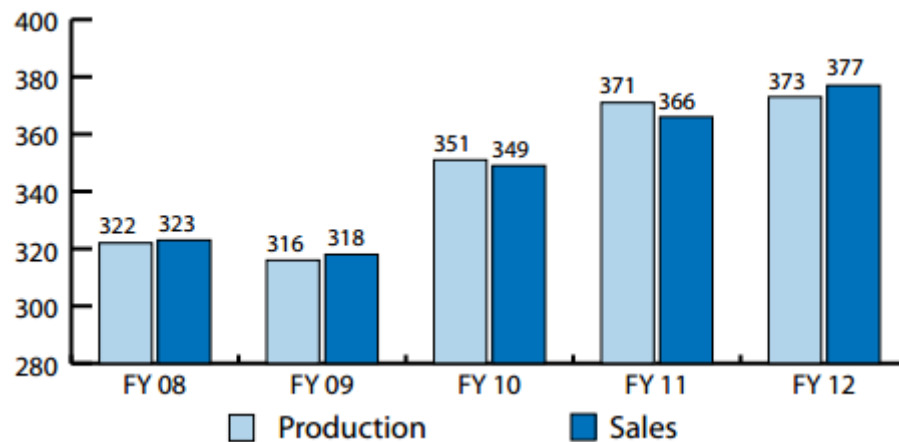

Figure 1.1 - Production and sales of hollow sections

Specifically the advantages obtained of using hollow section as a structural element are (Soares, 2012):

- Allows for the optimization of the structures' weight, resistance and stiffness, by only varying the hollow sections' thickness maintaining the outer diameter and the structure's geometry;
- Presents aerodynamic coefficients far inferior to the ones offered by open sections;
- Because of the round edges (or absence of them in circular hollow sections) the protection layer of paint can be applied much more evenly, ensuring a better corrosion protection;
- Can be reinforced by adding concrete to its interior, increasing the resistance to axial compression and fire;
- Can accommodate vent and drain systems in its interior;
- Excellent performance when subjected to compression, bending and torsion;
- Easiness of transportation, assemblage and dismantling of the structures' components.

However, the hollow sections also feature the following disadvantages:

- The production costs is higher than open sections;
- When the predominant internal force installed in the element is bending, much of the material does not contribute significantly to the element resistance, poor efficiency (if there is a lateral buckling problem this disadvantage becomes an advantage, since this type of problems are more prone to open sections);
- Due to its geometry, there is a certain difficulty to arrange connections that combines a good structural behavior with proper appearance.

1.2.2 Hollow circular section

According to Firmo (2005) by observing nature, there is the possibility of extracting teachings that are intrinsic to “things”, for example the bones, reed’s stalk, bamboo, etc. all tend to evolve and have the most efficient geometry for its structural purpose, the circular and/or tubular shape.

Amongst the tubular sections there are the circular hollow sections that have proven to be the best option for innumerable situations both structural and architectural. Regarding the already mentioned advantages for hollow sections, the following can be added by being characteristic to the circular hollow section:

- Lowest possible ratio between perimeter and its content, optimizing the material use (Firmo, 2005);
- By not having live edges, it has better aerodynamic behavior and produces “cleaner” lines offering reduced visual impact (Firmo, 2005);
- Since it has the same bending resistance in every direction, it is the best solution in elements that the loading direction can vary throughout its life expectancy.

The possible applications of circular hollow section structures are tremendously diverse. A structure of this type can be designed by an architect that wants simple lines and a smooth appearance in his work or it can also serve the intents of an engineer that is concerned with the weight of his project. The circular hollow section is implemented in buildings, roofing, bridges, offshore structures, communication towers, cranes, etc., this versatility can be seen in Figure 1.2 that shows some structures with a wide range of functions.



a) Luz's Stadium (Slbenfica@, 2014)



b) Roller Coaster (Theguardian@, 2014)



c) The atomium (Tarunchandel@, 2014)



d) Offshore oilrig (Newsledge@, 2014)

Figure 1.2 - Circular hollow sections structures

1.3 Objective

All of the structures referred meted challenges and obstacles throughout the development of their projects. Many of this obstacles are related with the connection of its different elements. Unfortunately the currently used connections' type threaten either the aesthetical potential of hollow section structures (top flange joint is a good example) or the structures economic (welded joints).

Every structural designer when working on a project must be aware of a large set of conditions, the assessment and combination of this conditions is a complex process that will produce a solution, the truss solution and the splice bolted connection presented in this thesis offer the following advantages:

- Truss structures have an optimized behavior and pleasing aesthetical appearance, gathering both engineer and architect consent;
- Hollow sectioned truss is the best solution to overcome large spans present in structures such as stadiums, airports and industrial complexes;
- The referred structures enable a high degree of pre-production that is limited by transportation dimensions, the splice connections offer a solution for this issue;
- The connection studied in this work is practically imperceptible, presenting an interrupted appearance.
- The connections offers a high performance solution.

This dissertation aims to study a connection that is an aesthetical, economic, easy to assemble which presents a good and predictable behavior solution that can be calculated using the practice formulations for connections submitted to cut efforts. Its basic geometry can be seen if

Figure 1.3.

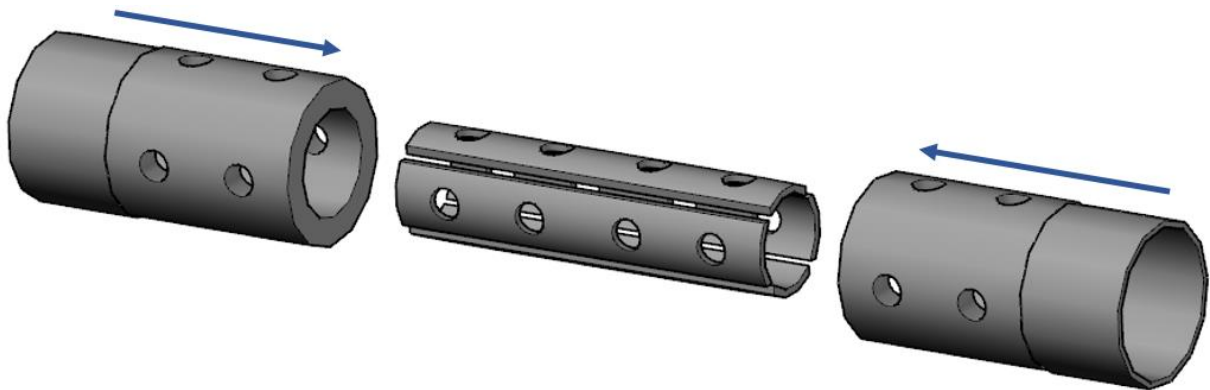

Figure 1.3 - Connection geometry

This dissertation is within the framework of a research investigation on the behavior of tubular splice joints, it is the last in line following a number of previous contributions: “Ligações em Estruturas Trianguladas com Perfis Tubulares de Secção Oca” (Dias, 2011), “Análise de Ligações em Perfis Tubulares com Parafusos de Cabeça Embutida” (Soares, 2011), “Avaliação Experimental de Configurações Inovadoras Para a Execução de Ligações de Emenda de Barras Metálicas de Secção Tubular” (Carvalho, 2012) and “Configurações Inovadoras de Ligações de Emenda de Barras Metálicas de Secção Tubular” (Freitas, 2013). The present work aims to

complete the research that was done until now, bearing in mind the problems and conclusions from the early works.

1.4 Thesis structure

This thesis encompasses 6 main chapters and 2 extra chapters that contemplate the bibliographic references and annexes. A brief description of the main chapters follows:

Chapter 1 – Introduction, in this chapter there is a brief framing of the importance and applications in the use of steel, narrowing down to hollow sections structures and followed by circular hollow sections, its applications advantages and disadvantages. Finalizing with the objectives set for the study.

Chapter 2 – State of the Art, the chapter that presents the historic evolution of steel use in what concerns construction, it is also mentioned the studies and investigations that led to the set of norms and regulations known as the Eurocode and investigation of bolted connections. Followed by the fastening possibilities, bolts types and the existing joints that are possible in tubular connections.

Chapter 3 – Experimental Procedure, is where the experimental analysis is described and the obtained results are discussed.

Chapter 4 – Numeric Procedure, the numeric modulation is presented in this chapter, as all the considerations that had to be taken into account in order to produce the models that represent the experimental component of the thesis. The obtained results are also discussed in the end of the chapter, comparing them with the ones obtained experimentally.

Chapter 5 – Analytic Procedure, in this chapter it's explained the shear bolt connection behavior. The connection is also calculated by the European regulations formulas present in the Eurocode 3, part 1-8, and then the results are analyzed.

Chapter 6 – Conclusions and Future Developments, the discussions and results obtained in previous chapters are presented. Also, it is suggested possible investigation and further development.

2 STATE OF THE ART

2.1 Historic evolution

Historically, the first use that man found in iron was to produce weapons and utensils for his everyday life, this is proved by archeological findings dating back to 1000 B.C., only till the 6th century there is evidence of iron tie bars incorporated in constructions, as in the arches of the Hagia Sophia in Istanbul. Later on, wrought iron was developed in the Middle Ages and its production method improved leading to a more widely use in constructions like dowels and ties to strengthen masonry structures.

Technological advancements thrived by the works of Abraham Darby led to the start of large-scale use of iron for structural purposes in Europe in the later part of the 18th century, proven by the Coalbrookdale arch bridge in England, created by Abraham Darby himself and dated 1779 (Figure 2.1).



Figure 2.1 - Iron Bridge Coalbrookdale (StudyBlue@, 2014)

The next relevant advancement happens in the second half of the 19th century, with the invention and patenting of a new process of making steel, by Sir Henry Bessemer. This new process, known as the “*Bessemer process*” led to a stronger, lasting and generally better quality of steel,

enabling the construction of bigger, more efficient and durable structures, leading to a steel construction impulse.

In the later part of the 19th century and beginnings of the 20th there was a relevant technological advancement regarding the quality and mass production of steel, this trend continues till the present moment offering, not just various grades of steel and alloys, but also structural solutions (Steel-insdag@, 2014).

2.2 Normative documents, research and publications

The crescent growth in steel constructions led to a broad range of problems and solutions, the hollow sections were one of the solutions. In spite the excellent behavior this type of solutions offers as a structural element, it is limited to some restraints, such its connections.

In 1951, due to the lack of information and studies regarding the present issue of the connections in hollow sections structures, W. Jamm brought forth the first set of recommendations to calculate connections between hollow sections in a truss structure (Wardenier *et al*, 2010).

With the increase in the use of hollow sections, especially in England, diverse theoretical and experimental studies start to emerge. Through the knowledge acquired a recommendation guide to improved project was produced in 1970. A year later this same guide was implemented and published in Canada by Stelco Inc with the name “Hollow Structural Sections – Design manual for connections” becoming the first written manual of connections between hollow sections (Resende, 2008). In 1973, with the objective of eliminating the bigger flaws and voids of knowledge and also compare the different data and formulations in existence, the task force *SG-TC-18* cooperating with the “Joint Group of CIDECT” set an extensive program of experimental research, testing approximately 450 connections (Carvalho, 2012). In the same period, other guides and manuals were published, a good example is “Limit States Design Steel Manual”, published by CUSC in 1997 (Resende, 2008).

The decade of 1980 provided the biggest leap regarding the study in connections between hollow sections, resulting in innumerable publications and manuals obtained by various experiments. From this publications and manuals the ones edited by the internacional association CIDEC – Comité Internacional pour le Développement et l’Etude de la Construction Tubulaire stand out. This association is composed by the leading international producers of tubular sections, it was created with the objective of expanding the knowledge and know-how, via adequate experimental studies, of hollow sections and its applications in the construction industry.

The investigation went on in the 1990 decade, the concern was to improve the existent formulation by obtaining simpler and more concise new formulas. Through the newly implemented computer technology, the first numerical studies start to emerge like the finite element method (Resende, 2008). In 1992 CISC – Canadian Institute of Steel Construction, published a new and more complete manual about hollow sections steel structures and its connections, the manual was named “Hollow Structural Section: Connection and Trusses – A design Guide” (CISC, 2014).

In the year 1975, the European Commission adopted a decisive course of action in the field of civil construction. The aim was to eliminate any technical difficulties to the commerce of products and services inside the European Union, by elaborating a set of standard technical regulations for the structural project of buildings and other civil engineering enterprises, this regulations became known as the Structural Eurocodes. In 2007 was published the last of the 58 parts that constitute the 10 European Standards, also till this day there’s a continued improvement in this field of regulation (LNEC@, 2014).

From the 10 standards referred previously, there is one that specifically targets steel structures the Eurocode 3: Design of steel structures. The part that concerns this thesis field of study is the Part 1-8: Design of joints.

Studies and research in the field of joints between hollow sections show a clear tendency to welded type connections, leaving little profound knowledge compared to the other types, such as the one being studied in this dissertation: the bolted connection. However as it may be, the most relevant studies in the evolution of in-line connections are presented next.

In 2003 a research led by Packer and Lecce investigated in-line connections by nailing, there were static tests and fatigue tests. Various models were tested varying parameters such as: hollow section resistance, number of lines of nails and tube thickness. To obtain detailed results several failure modes were tested, the ones important to refer are: shear, bearing and plate tension. The nail type used and experimental setup can be seen in Figure 2.2- a) and b) respectively.

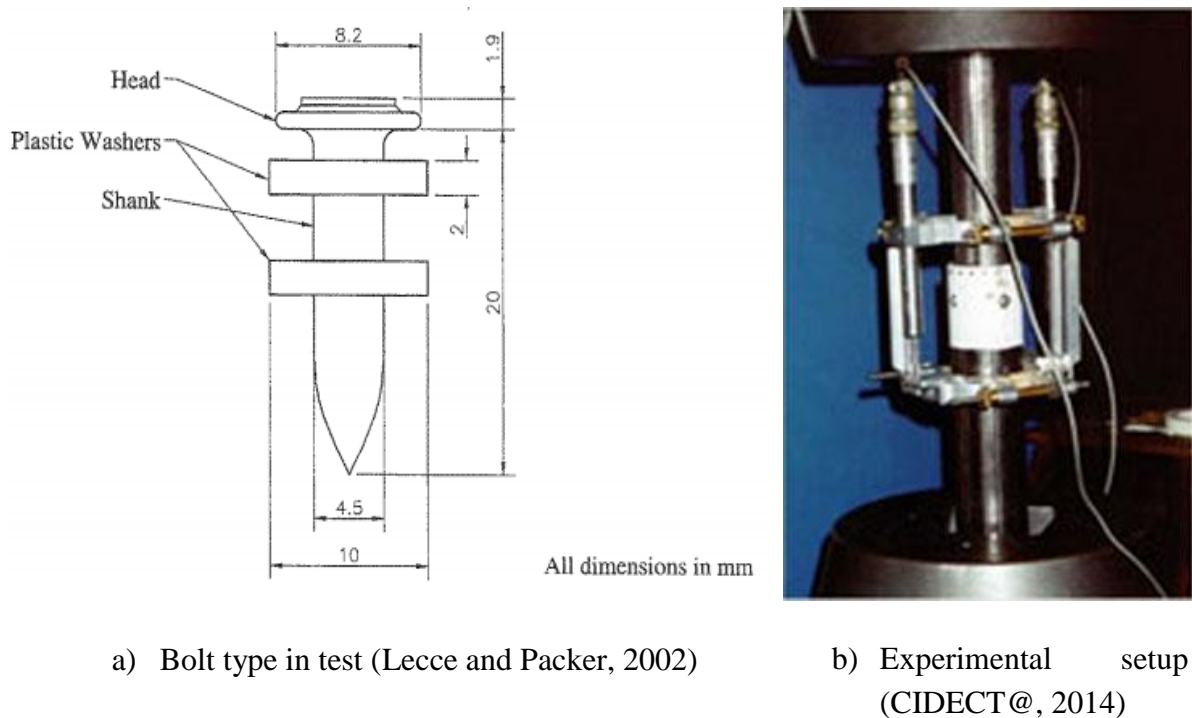

Figure 2.2 - Peccer and Packer nailed connection

The expected resistance of each failure mode was obtained from previous studies of this type of connection, the following first 3 formulas express that:

$$V_u = (\text{shear strength of nail}) \cdot n \quad (1)$$

$$B_u = 3 \cdot D \cdot t \cdot n \cdot F_u \quad (2)$$

$$T_u = A_{ne} \cdot F_u \quad (3)$$

$$A_{ne} = A_g - D \cdot n_r \cdot t \quad (4)$$

In which (1) is the shear resistance being n the number of nails, (2) the bearing resistance of the hollow sections and (3) the tension resistance, the D is the diameter of the nails, t the thickness of the hollow sections, F_u the yield tension of the steel used in the hollow sections and A_{ne} the effective shear area.

In 2007, Kim, Yoon and Kang set themselves to the study and analysis of finite elements models of bolted joints. This research had 4 distinct models: solid bolt model, coupled bolt model, spider bolt model and no-bolt model, the appearance of the models are shown in Figure 2.3. Through a static and dynamic analysis it was concluded that the best way to simulate the correct physical behavior and with more precision was to use a solid bolt model, comparing to the other

models, the solid bolt model led to more precise results at the expense of longer calculus durations (Kim *et al*, 2007).

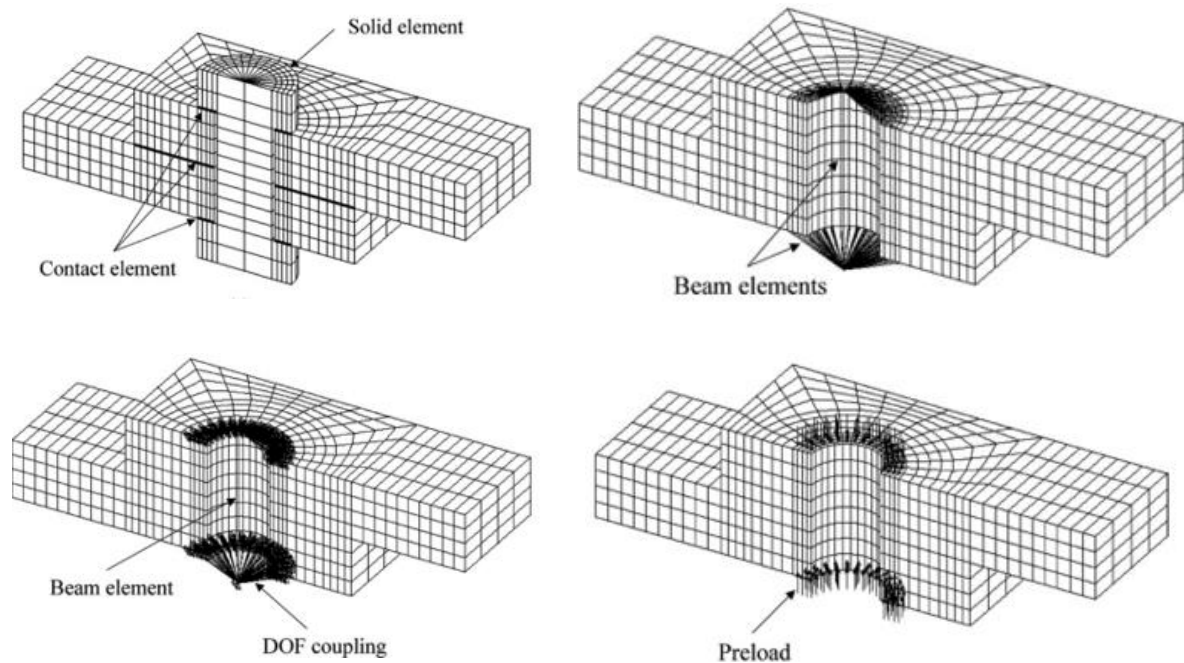

Figure 2.3 - Diferente numeric models (Kim *et al*, 2007)

In the year 2009, Dusicka and Lewis tested a new solution with pre-tensioned high strength steel bolts with filling plates. The study aimed to vary the thickness of the filler and hole diameter and getting the results by observing the deformation, joint resistance in general and the sliding force between plates. The most important conclusion attain was that with the increasing thickness of the filling plate the connection resistance tended to decrease till it reached a certain limit, from which it could regain resistance by thickening the other plates. The experimental model is displayed in Figure 2.4 (Dusicka and Lewis, 2009).

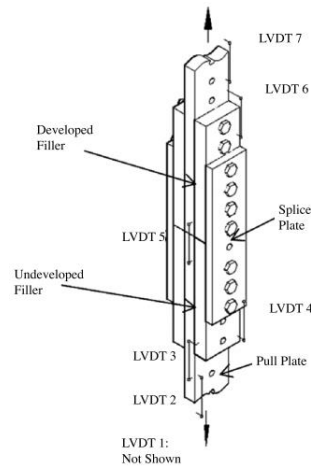

Figure 2.4 - Bolted assembly layout (Dusicka and Lewis, 2009)

In the same year of 2009, an investigation led by Williams *et al* (2009) targeted the issue of numerically modeling pre-stressed bolted connections through the use of finite elements models. The study compared experimental models, finite elements models and analytical approaches. The relevant conclusion for this dissertation is that certain detailed features, such as the thread interaction between bolt and screw that are complex and time consuming to model, do not need to be considered in the model for it to ensure satisfactory results, see Figure 2.5.

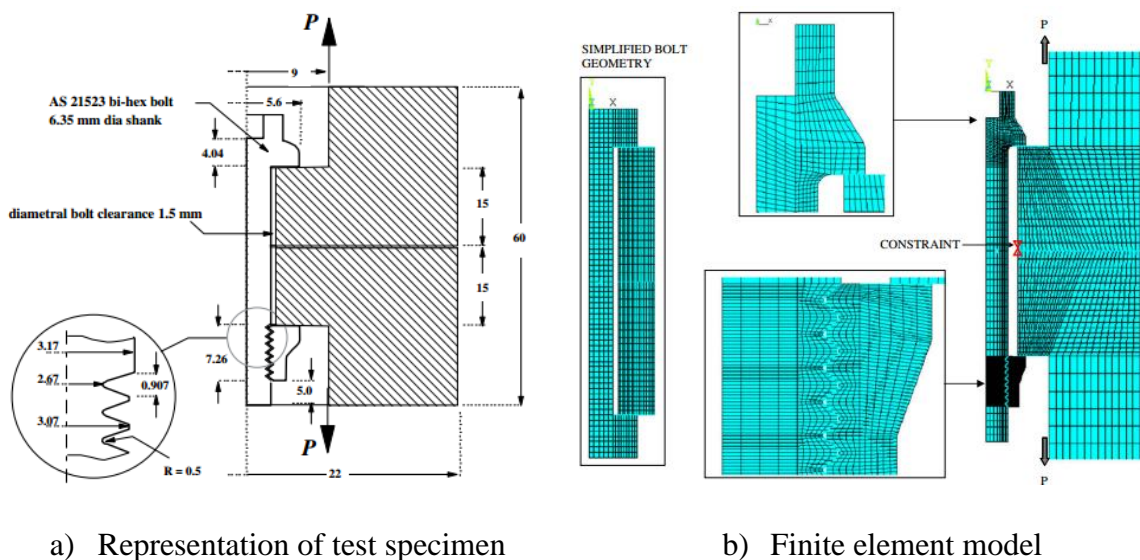
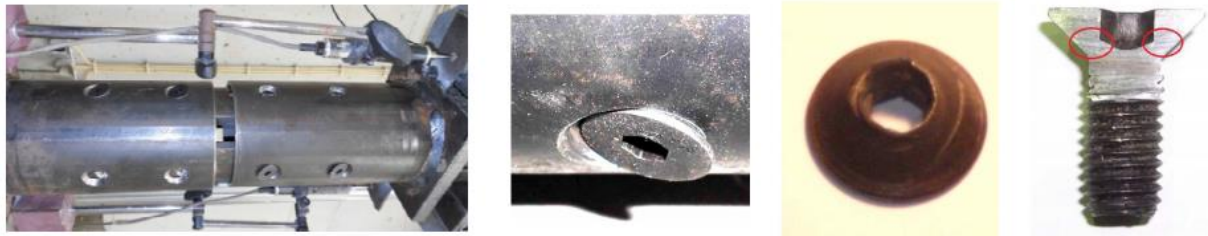

Figure 2.5 - Numeric study of bolted connection (Williams *et al*, 2009)

As referred in the first chapter, this thesis is the latest work regarding the investigation started in 2011 by Dias. The works of Dias (2011), Carvalho (2012), Soares (2012) and Freitas (2013) are summarized in the article: Behavior Evaluation of In-line Connections in Hollow Sections

(Rui Simões *et al*, 2013). During this investigation the diverse solutions are analyzed through experimental testing, numeric models and analytical formulations. The conclusions, reported in the mentioned article, affirm that to ensure acceptable connection stiffness and to mobilize stresses the right way in the components, the bolts can't be allowed to rotate perpendicularly to their longitudinal axis. This ensures a predictable behavior by an analytic approach using the formulations in the Eurocode 3 Parte 1-8 for shear connections, therefore facilitating the resistance calculation of each connection component. In order to guarantee the non-rotation of the bolts, they must have a socket head (to produce a prying effect) or in case of countersunk screw the thickness of the outer hollow section must be increased, the hollo-bolts were discarded as a good solution due to the low stiffness they gave the connection. To better the solution the inner hollow section should be sectioned in 4 parts lengthwise, see Figure 2.6



a) Experimental research

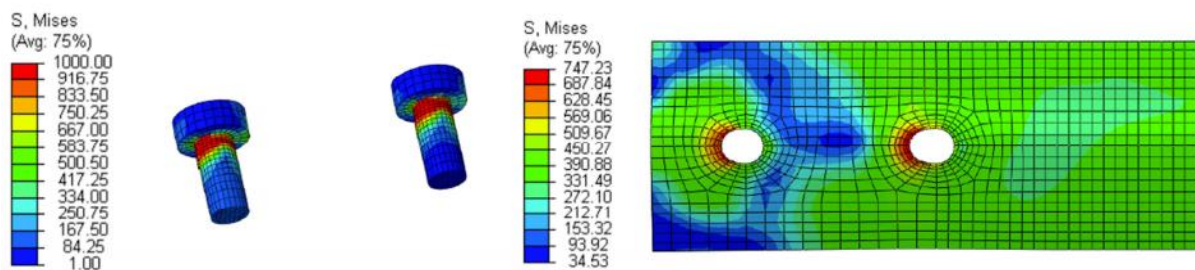

b) Numeric analysis

Figure 2.6 - Splice connection study (Rui Simões *et al*, 2013)

2.3 Existing splice connections between hollow sections

2.3.1 Introduction

Connections can be differentiated in 3 major groups:

- Riveted connections;
- Bolted connections;
- Welded connections.

The riveted connections, despite of their popularity in the earlier years of steel structures, are being replaced gradually by bolted connections, this is due to its high installation costs, relative weak strength of the rivets and the general inefficient of the riveted connection. Regarding the welded solution it has advantages such as not having holes and thus making it more efficient, but its production in the construction site is highly difficult presenting a technical challenge and time consuming operation leading to increased costs, also it is very susceptible to cracking induced by fatigue due to cyclic loads, such as trains or earthquakes (Santha Kumar and Satish Kumar, 2014).

Bolted connections increasingly usage is due to its inherent advantages, such as:

- Easily fabricated and assembly in the construction site;
- Less expensive than a welded solution;
- Less execution errors in the construction site;
- Relative good behavior to fatigue;
- Ease of inspection and replacement of any element while the structure is in service.

An important phase of any project is transporting the structural components to the construction site. Being limited to certain dimensions, depending on the means of transportation, the structure is moved by modules that need proper planning to ensure an inexpensive transportation. To assemble the different modules, the splice bolted connections take on an important role ensuring an easy montage in a steel structure project.

To further the connections denomination, it's possible to refine the typologies dividing them according to the internal force that occur in the bolts, shown in Figure 2.7:

- Shear connection;
- Prestressed connection;
- Tension connection;
- Tension and shear connection.

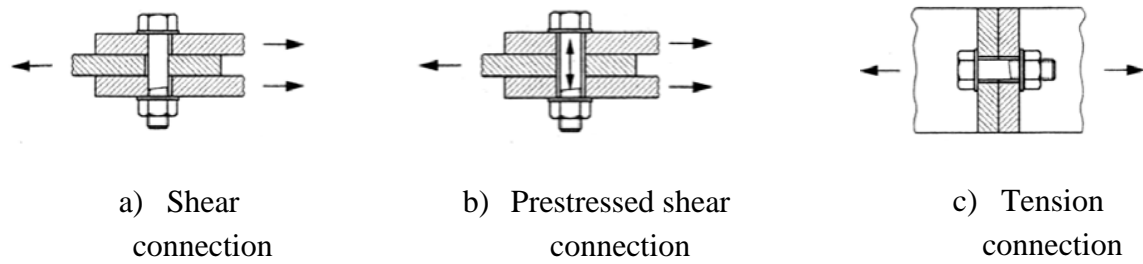

Figure 2.7 - Connection type according to mobilized internal forces (Simões da Silva, L. e Santiago, A., 2003)

The different failure types in bolted connections are represented in Figure 2.8.

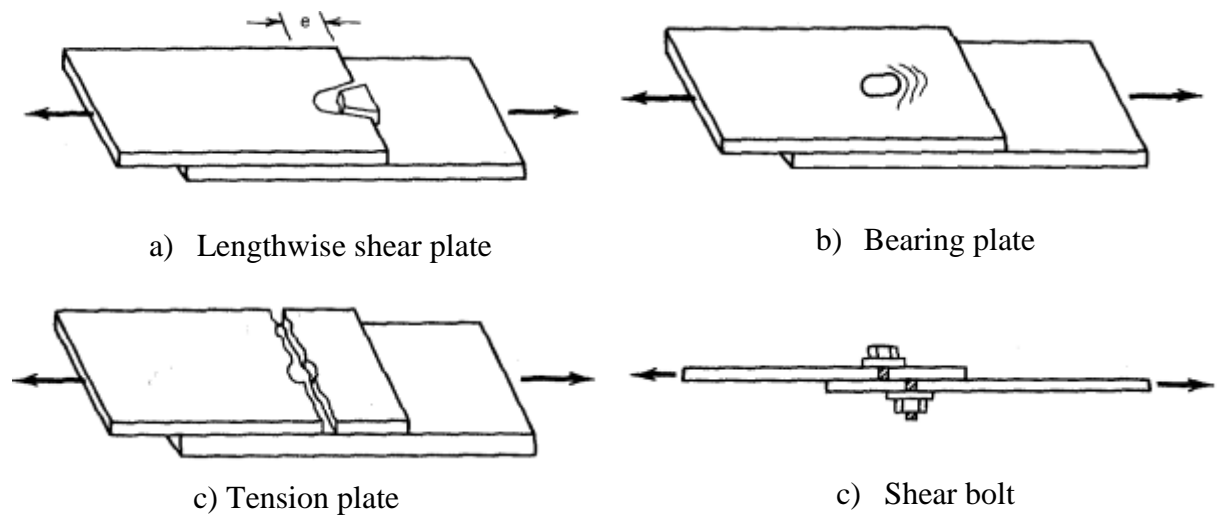

Figure 2.8 - Failure modes in bolted connections (Simões da Silva, L. and Santiago, A., 2003)

2.3.2 Bolts

Bolts offer a broad range of shapes, dimensions and fastening manners, choosing between them depends on the best solution to the given problem. The most common shape being used nowadays is the hexagon bolt head. The diversity of bolt typologies can be seen on Figure 2.9.

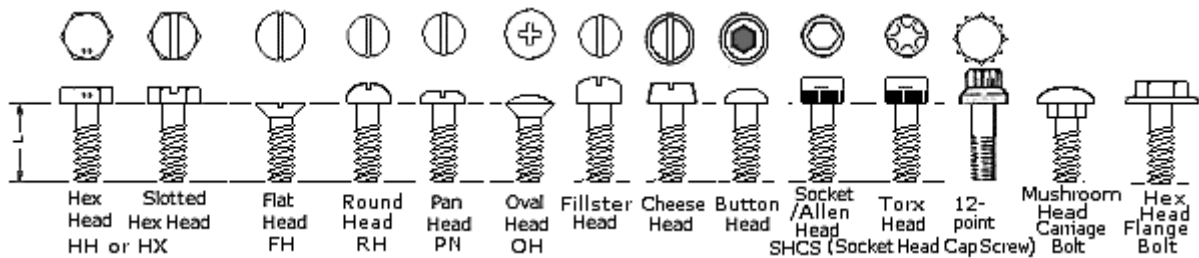
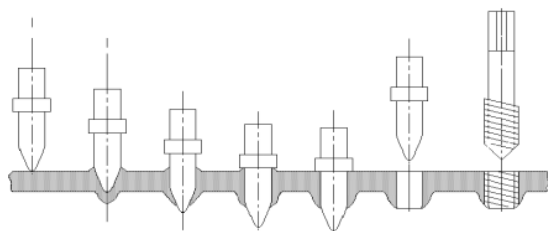
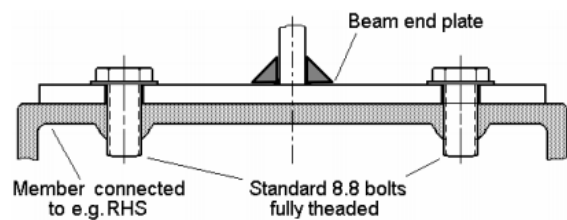

Figure 2.9 - Bolt types (Donsnotes@, 2014)

The major technical difficulty regarding bolted connections of hollow sections is the lack of access to the bolts in order to secure the fastening, many times, only the head of the bolt is accessible. Some solutions have been developed to solve this difficulty like the blind bolting systems (fastening with one side access only), represented in Figure 2.10.



a.1) Flowdrill Process



a.2) Beam-column connection using flowdrill

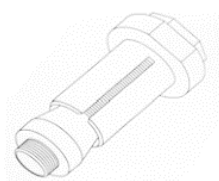

b.1) Lindapter hollo bolt

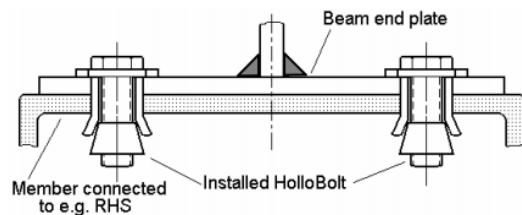

b.2) Beam-column connection using hollo bolt



c.1) Exploded view of Huck Ultra-Twist bolt

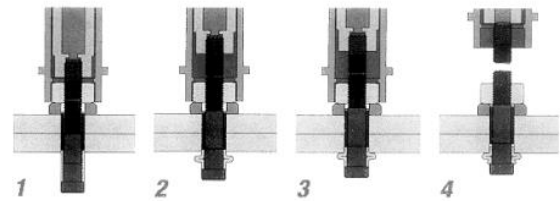

c.2) Installation procedure

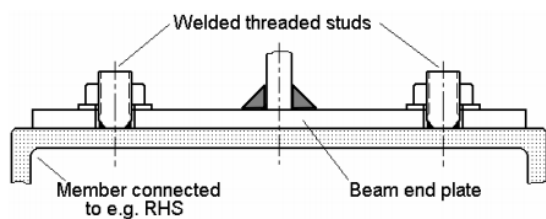

d.1) Welded threaded stud

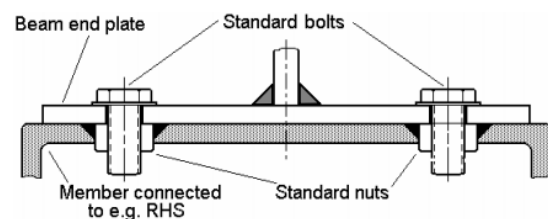

d.2) Nuts welded into hollow section wall

Figure 2.10 - Blind bolting systems (Simões da Silva, L. e Santiago, A., 2003)

According to Dutta *et al* (1998), the blind bolting systems are not a common practice mainly due to the fact that the commercial diameters are too small for structural use, this is a decreasing trend mainly because there are diameters up to M24.

Nevertheless the advantages offered by blind bolting, the system chosen for this study is a simpler one.

2.3.3 Flange-plate Joint

The flange-plate joint is the most common solution for an in-line connection of two hollow sections due to the practicality and ease of execution both in structural montage and prior to it. Also there's an extent research regarding it, pointing out Kato & Hirose (1984), Igarashi *et al.* (1985) and Cao & Parker (1998). Supported on Igarashi's research Wardenier *et al.* (2008) devised a calculation guide for CIDECT. Also supported on the same researches are dimensioning details present in the "Japanese Recommendations for the Design and Fabrication of Tubular Truss Structures in Steel" (Wardenier *et al.*, 2010).

This joint type consists of welded plates orthogonal to the structure elements length axis, both plates are then bolted together, see Figure 2.11. There are 3 components that have to be analyzed in this connection:

- Bolt in tension;
- Weld failure
- Plate submitted to punching shear;
- Bending plate due to lever mechanisms (prying).

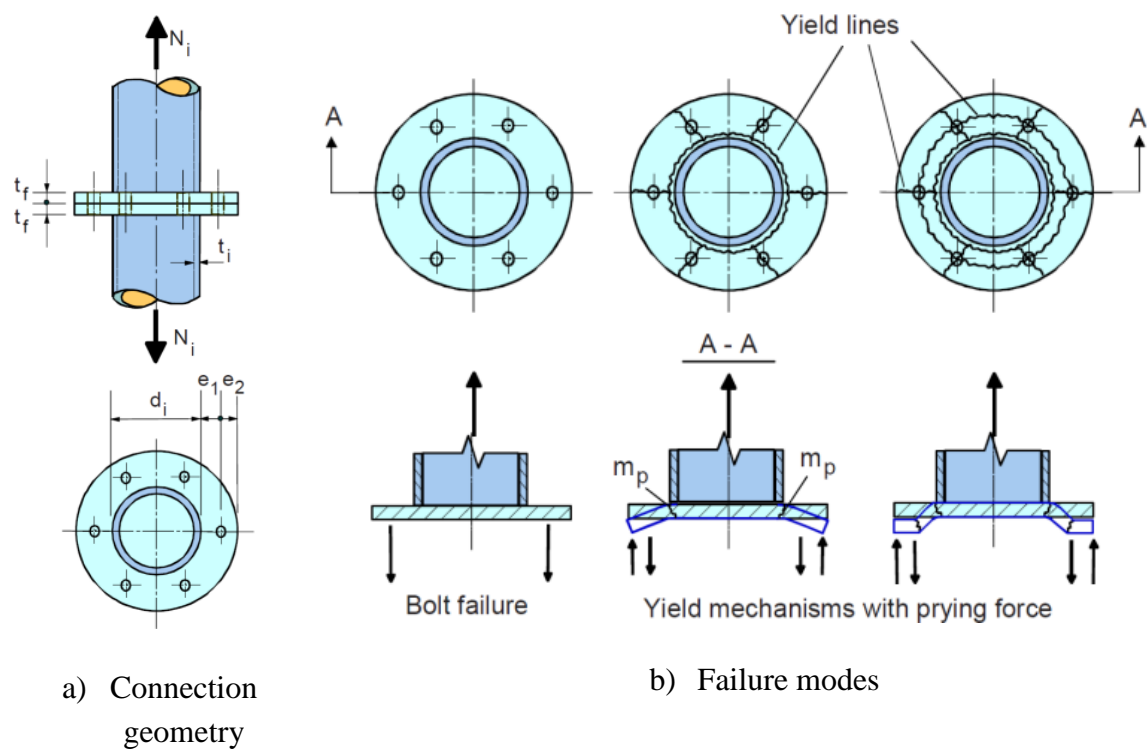

Figure 2.11 - Flange-Plate Joint (Wardenier, 2010)

This solution offers a high structural performance but lacks aesthetical attributes.

2.3.4 Lateral plate connection

The joint consists in plates welded lengthwise on the periphery of the hollow sections, these plates are then connected using fish plates on either side, ensuring a proper transfer of load, as shown in Figure 2.12. This solution is suitable for significant loads and large loads, special attention is required to corrosion (Duta *et al*, 1998). The components that need to be analyzed are:

- Bolt shear;
- Weld failure;
- Bearing plate;
- Plate in tension;

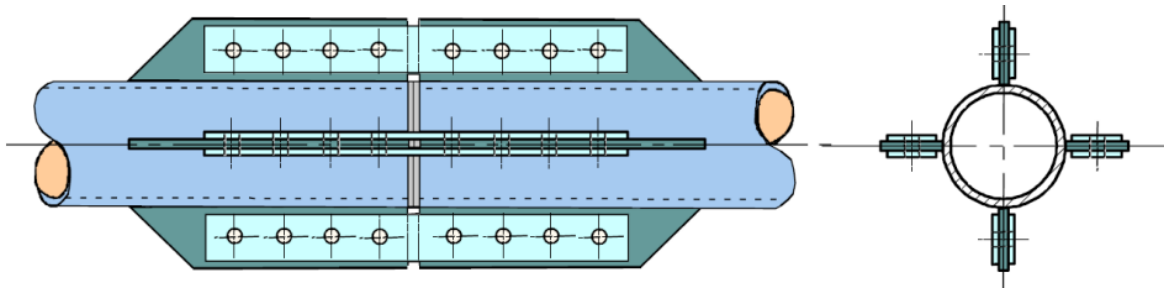
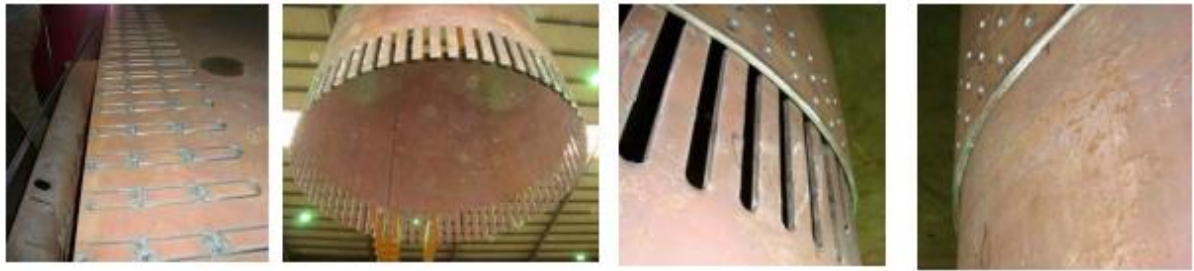

Figure 2.12 - Bolted splice joint (Wardenier, 2010)

This solution is not very common due to its high complexity and coarse appearance.

2.3.5 Friction joint with high resistance bolts

A perfect example of an in-line connection situation often occurs in the wind turbine support structure. The HISTWIN project is developing and researching a solution that is able to connect the different modules of a wind tower, this connection is achieved by creating opened slotted holes in the lower segment, where as the top segment has preinstalled high strength bolts, by sliding them together and then fastening to the predetermined strength, the connection works through friction between the contact surfaces of the segments (higher the fastening strength, higher the mobilized friction), to better comprehend this connection follow Figure 2.13.



a) Production and assembling of the friction connection with open slotted holes

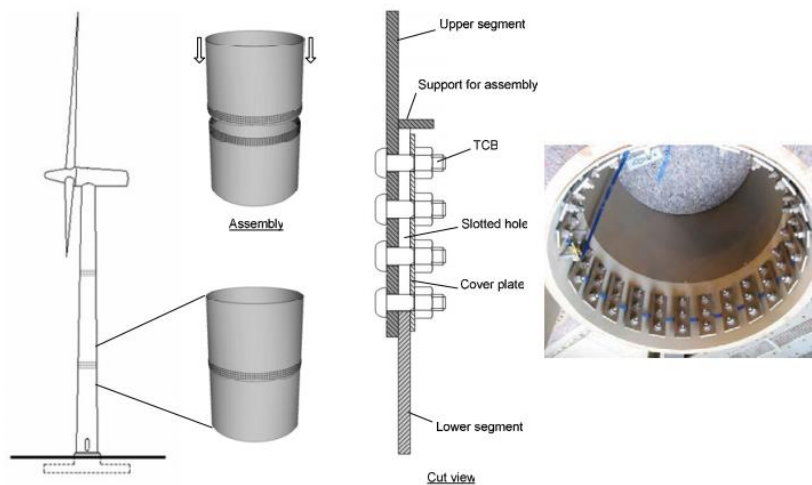

b) Main concept of the friction connection in tubular tower for wind turbines

Figure 2.13 - Friction joint with high resistance bolts (HISTWIN, 2009)

The difference between most similar connections, is that the bolts are only subjected to tension, being the efforts transferred via friction. The easiness of execution comes from the sliding assembly and pre-assembled fasteners (HISTWIN, 2009).

2.3.6 Nailed connection

The connection consists in two hollow sections, one is larger than the other in a manner that the outer diameter of the smaller hollow section is the same as the inner diameter of the bigger hollow section. The hollow sections are nailed together with symmetrical attention to ensure a proper effort transfer. The hollow sections can also have the same diameter and be connected with a collar that is nailed to them, as shown in Figure 2.14.

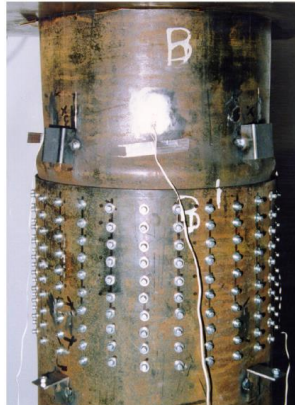

Figure 2.14 - Nailed hollow section connection (Wardenier, 2010)

According to Leccer and Packer, 2002, the connection as the following failure modes:

- Nail shear;
- Bearing of the base metal;
- And net section fracture.

Studies led by Wardenier 1995, and Packer 1996, concluded that nailing is a viable solution to connect two hollow sections, it is also inexpensive and simple to execute because it doesn't require electric power nor specialized technical man-power (Lecce and Packer, 2002).

3 EXPERIMENTAL PROCEDURE

3.1 Introduction

One of the main goals of this solution is to offer a simple connection, which provides a predictable behavior described by the formulations present in the Eurocodes. The solution, is having the inner plates acting similar to a nut, and thus having a threaded hole, the outer thick tube has a countersunk hole or a socket hole, for the countersunk bolt or socket head bolt.

The discrete appearance of the bolts provided by their holes serves several purposes. At one hand the holes offer enclosure to the bolts increasing drastically the contact area between hollow sections and bolts ensuring an improved transfer of forces and thus increase significantly the hollow section's bearing resistance, on the other hand the bolt is much more sheltered to the elements and possible corrosion agents also providing a disguised connection that has a regular appearance and is aesthetical appealing as shown in Figure 3.1.



Figure 3.1 – Bolt appearance in connection

The experimental procedure aimed to reproduce the conditions of the connection in study, this is achieved by producing test specimens submitted to pure tension using a universal test machine. The specimens aimed to be in line with common practices, such as bolt diameters and typologies, hollow sections and steel grade.

There were restrictions that narrowed the options like the load capacity of the machine being limited to 600kN and the hollow sections diameters had to be available in the company producer's stock. The bolts typologies were chosen to address the concealed appearance of the connection, therefore the bolt's head should be embedded and still have the ability to be

fastened. Two failure modes will be expected, combining with two bolt types results in 4 set of specimens (shown in Figure 3.2 and **Erro! A origem da referência não foi encontrada.**), in order to obtain the two failure modes separately, some preliminary calculations produced the geometries exposed in the following sub-chapter. For future reference: SH – socket head; CS – countersunk, t – inner plate thickness. It was produce sets of 2 specimens each.



a) Inner plates



b) Outer component



Mid assembly specimen

Figure 3.2 - Components of a specimen

Table 3.1 - Specimens Parameters

		Set tests			
		1	2	5	6
Specimen name		M12-SH-t6	M12-CS-t6	M16-SH-t6	M16-CS-t6
Foreseen failure mode		Bolt shear		Plate tearing	
Bolt type		Socket head	Countersunk	Socket head	Countersunk
Bolt diameter		M12	M12	M16	M16
Bolt class		8.8	8.8	10.9	10.9
Hollow sections Dimension [mm]	Inner plates	6	5	5	5
	Hollow Section	120x4			
	Outer Hollow section	121x20			
Steel hollow section's class		S275			

3.2 Specimens definition

3.2.1 Geometry

The outer component is composed by the hollow section welded to the thicker mechanical hollow section, this piece is then welded to thick plates intended to serve as handles that enable the introduction of pure axial tension by the grip of the test machine. The resulting outer part geometry, with its respective holes, is defined in Figure 3.3 and Figure 3.4.

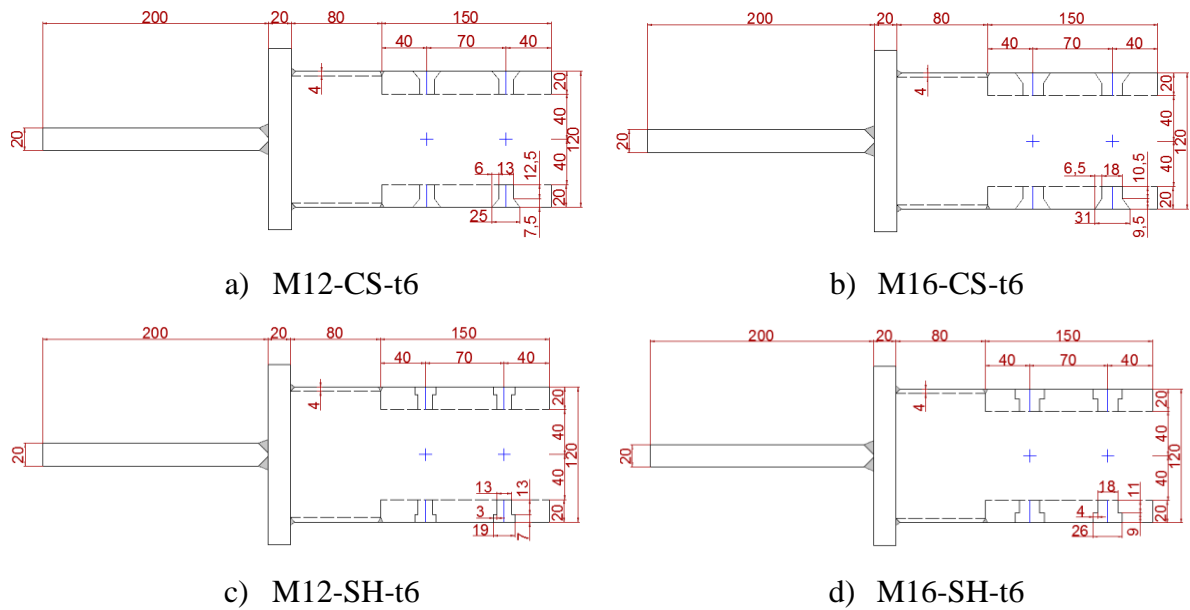

Figure 3.3 - Side view of outer components and dimensions

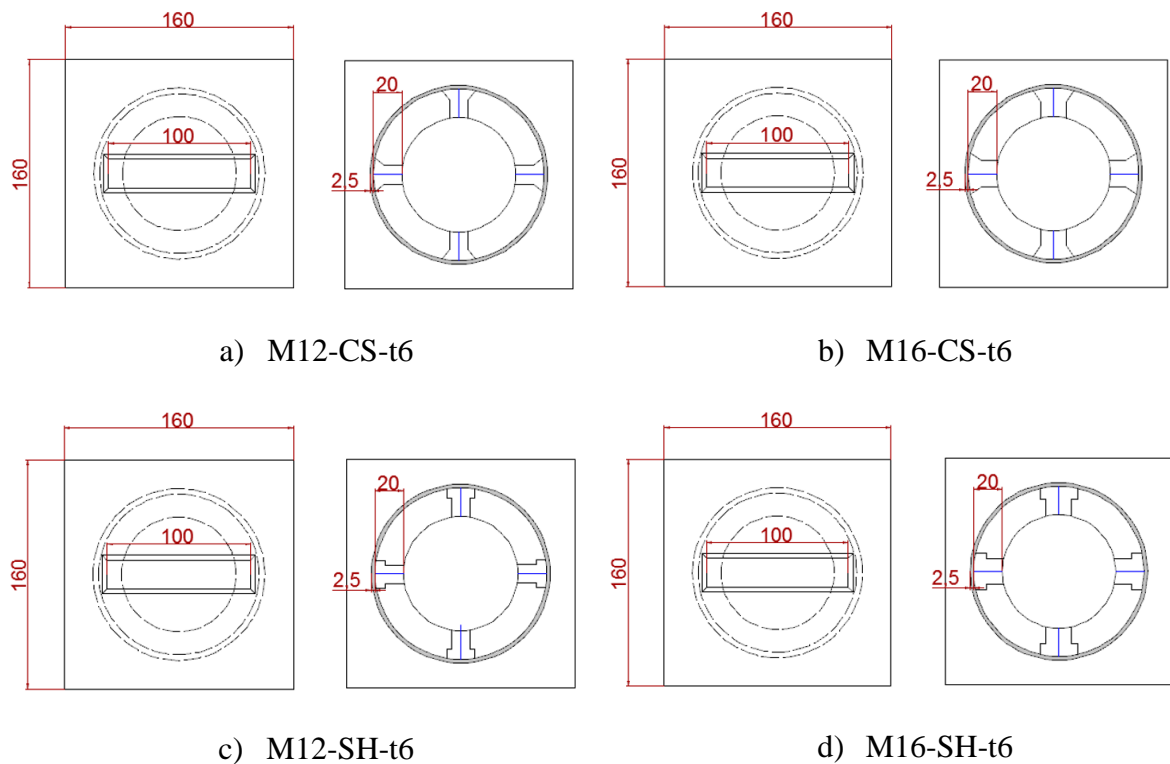
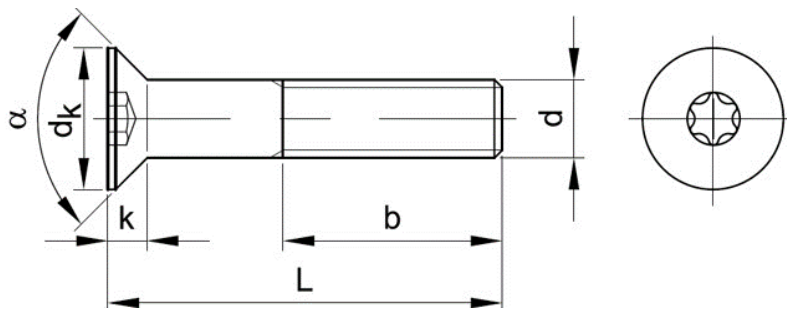

Figure 3.4 - Front and back views of outer components and dimensions

The four chosen bolts types are described in Figure 3.5 and Figure 3.6. The length ensured more than one and a half screw lap, for the threaded portion it had to cover the plate threaded hole. The geometry can be visualized in the following figures.



Type	M12	M16
d [mm]	12	16
b [mm]	27.5	26.2
l [mm]	35	35
k [mm]	7.5	9.5
dk [mm]	24	29
α [°]	77	69

Figure 3.5 - Countersunk screw dimensions

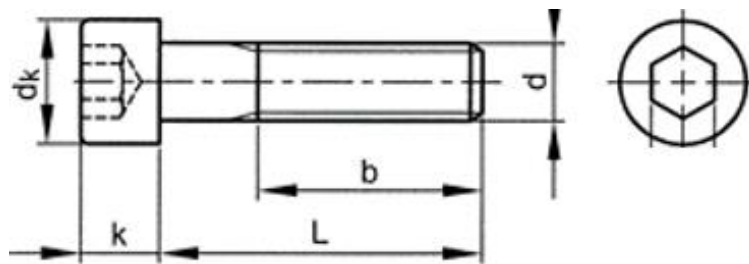

Type	M12	M16
d [mm]	12	16
b [mm]	30	30
l [mm]	30	30
k [mm]	7	9
dk [mm]	18	24

Figure 3.6 - Socket head screw dimensions

For the inner plates, to simplify the fabrication and assembly process, instead of sectioning a tube in four lengthwise it was decided to bend a flat plate with the desire dimensions to match its outer diameter with the inner diameter of the outer hollow section, and then proceed to drill the threaded holes. The bending of the plates will deform the piece, but this deformation will affect the fibers that are orthogonal to the stress solicitations not reducing the plate’s resistance significantly. The following Figure 3.7 show the pieces pre-bending and assembled post-bending.

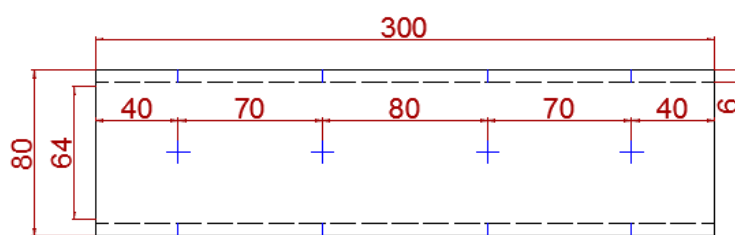

a) Side view pre-bending

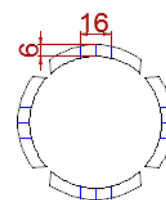

b) Side view post-bending assembled

Figure 3.7 - Inner plates dimensions

3.2.2 Mechanical properties of the material

There are 5 types of steel being used in this study each of them assigned to: the hollow section (or structural tube), the mechanical thick tube, 10.9 bolts, 8.8 bolts and the inner plates. Their nominal resistances are presented in the following table.

Table 3.1 - Nominal values for tensile steel strengths

Component	Bolt 8.8	Bolt 10.9	Mechanical Tube	Plates and Structural Hollow section
Steel	8.8	10.9	S 355	S 275
Yield tensile strength [MPa]	640	900	355	275
Ultimate tensile strength [MPa]	800	1000	510	430

3.3 Instrumentation

To better understand the physical phenomena occurring throughout the testing, different types of data were recovered for analysis: the overall connection displacement, the mechanical pull force applied by the machine and the localized strains. The mechanical pull measurements are provided by the machinery itself. The overall displacement is measured by displacement transducers that are located in diametrically opposed positions ensuring the detection of eccentric displacements (in case they occur), the setup can be seen in Figure 3.8.



Figure 3.8 - Experimental setup

As to the local strains, they were measured using extensometers positioned in key positions. These positions were determined based on the stress field and stress pathways. In Figure 3.9 it's possible to observe a stress concentration near the holes hence the need to ensure extensometers near them, it is also predictable to witness bearing deformations hence the need to have an extensometer where the hole is compressed.

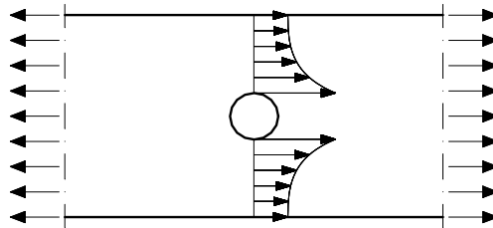

Figure 3.9 - Concentration of tension next to a hole (Simões *et al*, 2010)

Since all internal forces are transferred through the plates there is also an extensometer where the maximum stress is foreseen, in other words in the plate's middle. To detect eccentricities there were predicted one more extensometers in the same position in opposite plate. The outer piece is only instrumented in the hollow section, not being predictable significant deformations in the mechanical tube. Only one specimen of each test is instrumented with extensometers. The extensometers have strain limit of about 3%. Its identification and their exact position can be seen in Figure 3.10, Figure 3.11 and Figure 3.12 and Table 3.2.

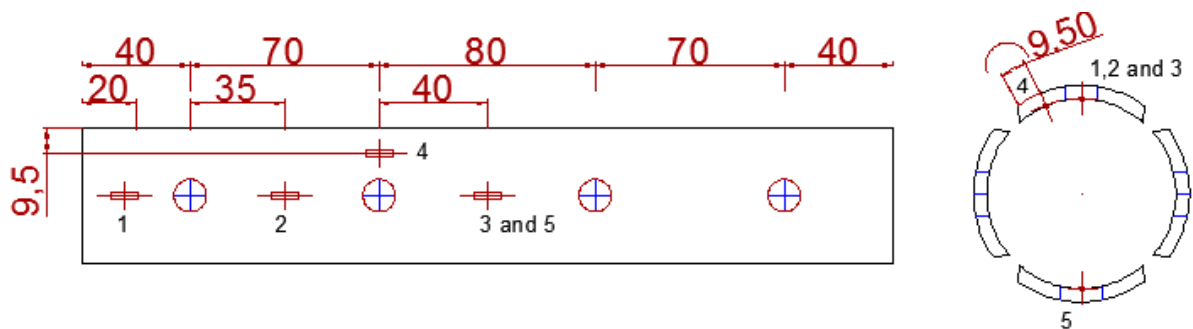

Figure 3.10 - Extensometers location in the inner plates (bolt shear test, M12 bolt)

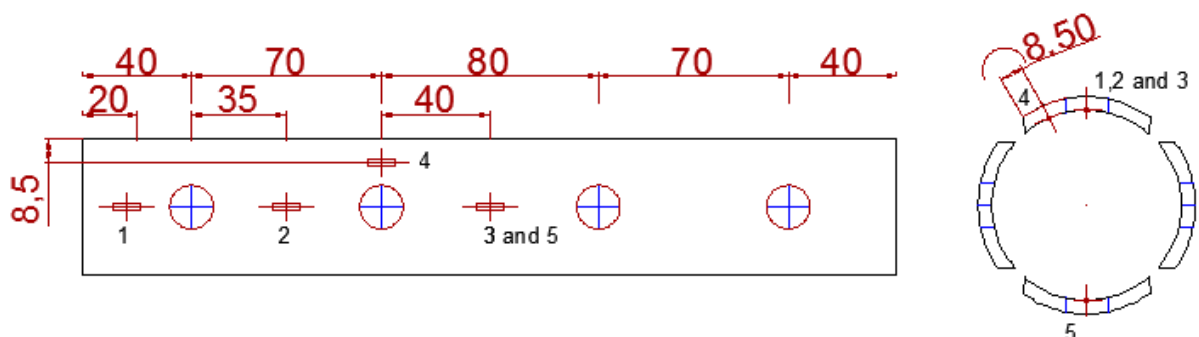

Figure 3.11 - Extensometers location in the inner plates (plate tearing test, M16 bolt)

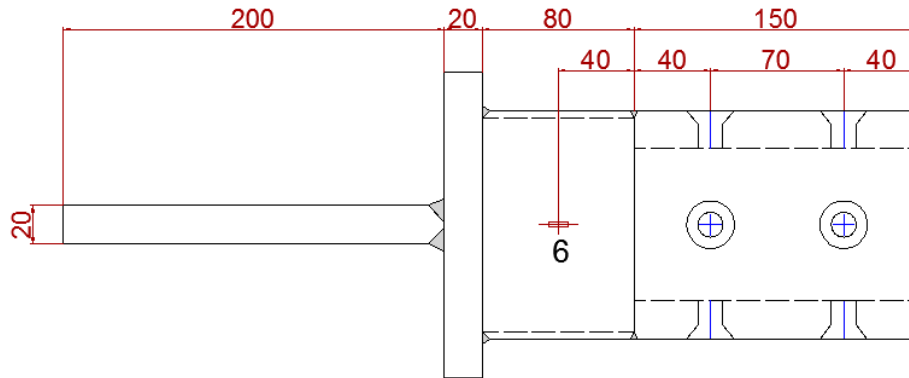

Figure 3.12 - Extensometers location in outer element

Table 3.2 - Extensometers position and type

Position	Bolt Shear Test		Plate Tearing Test	
	M12-SH-t6	M12-CS-t6	M16-SH-t6	M16-CS-t6
1	FLK-6-11	FLA-6-350-11	FLA-3-11	FLK6-11
2	FLA-6-350-11	FLA-6-350-11	FLA-3-11	FLK6-11
3	FLA-6-350-11	FLA-6-350-11	FLA-6-350-11	FLK6-11
4	FLA-6-350-11	FLA-6-350-11	FLA-3-11	FLK6-11
5	FLA-6-350-11	FLA-6-350-11	FLK6-11	FLK6-11
6	YFLA-5	FLA-6-350-11	YFLA-5	YFLA-5

3.4 Experimental setup and test protocol

The tests started with the non-instrumented specimens that would need less force to reach failure, the specimens that would fail by bolts in shear. Followed by the instrumented specimens and then, the same procedure for the plate tearing test.

The specimens are positioned in the universal testing machine fitted with the displacement transducers and extensometers that are connected to a data logger that will register the data throughout the test. After the setup is assembled, it is issued an order to the machine that induces a steady displacement at 0.015mm/s speed, this displacement over time is independent of the strength needed to keep the referred speed, the test stops after failure is attained.

3.5 Results analysis

3.5.1 Introduction

With the instrumentation previously referred it is possible to obtain data that allows the analysis and description of the physical phenomena occurring, this data is:

- Applied strength over time;
- displacement over time;
- strain in referred key points.

The gathered data is treated and presented in graphics to better understand it, complemented with visual analysis of the specimens post testing.

3.5.2 Failure modes

Both intended failure modes can easily be confirmed by visual assessment of the connections components after the tests. For shear bolt tests it's possible to see in Figure 3.13 a clear cut plane in both types of bolts and a small hole elongation.



a) Countersunk bolt sheared



b) Socketed head bolt sheared



c) Slightly elongated hole in inner plat

Figure 3.13 - Components after shear bolt testing

As for the plate tearing test, the plates ruptures is evident in Figure 3.14, the used bolts are intact throughout the test (both types). Tearing occurs in the inner hole because it's the first bolt that transmit the effort to the outer tube, hence transmitting part of the effort that the second bolt (or outer bolt) transmits to the tube.



a) Intact bolts

b) Teared plates in joint



c) Teared inner plate

Figure 3.14 - Components after tear plate testing

3.5.3 Tension-displacement curves

The most important characteristic that describes the connection behavior is the curve that relates force with displacement, through the measurements given by the test machine (tension strength) and the displacement transducers (overall displacement) the referred curve was obtained, see Figure 3.15, Figure 3.16, Figure 3.17 and Figure 3.18. The results between the tests sets do not differed significantly to the point of being needed a third one.

The first two set tests have M12 bolts that led to connection failure by shearing the connections bolts, the other two sets have M16 bolts producing the plastic yield of the inner plates.

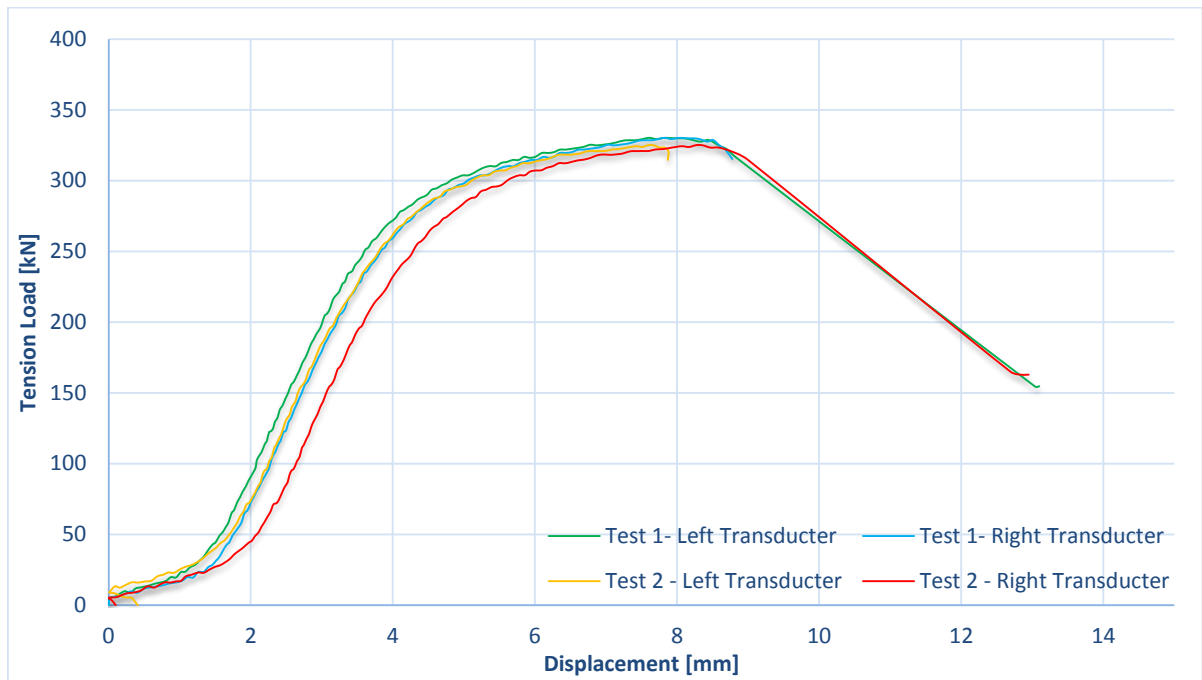

Figure 3.15 – Set 1 , Bolt shear test (Countersunk M12)

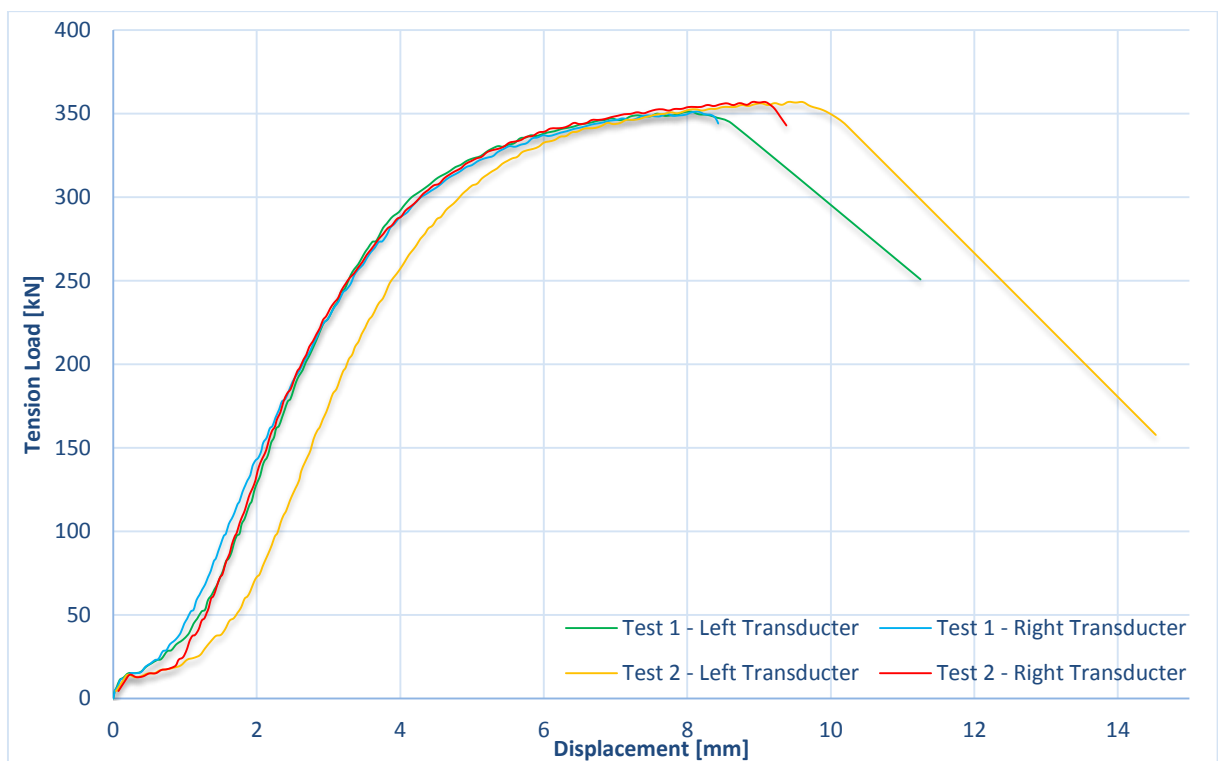

Figure 3.16 – Set 2, Bolt shear test (Socket Head M12)

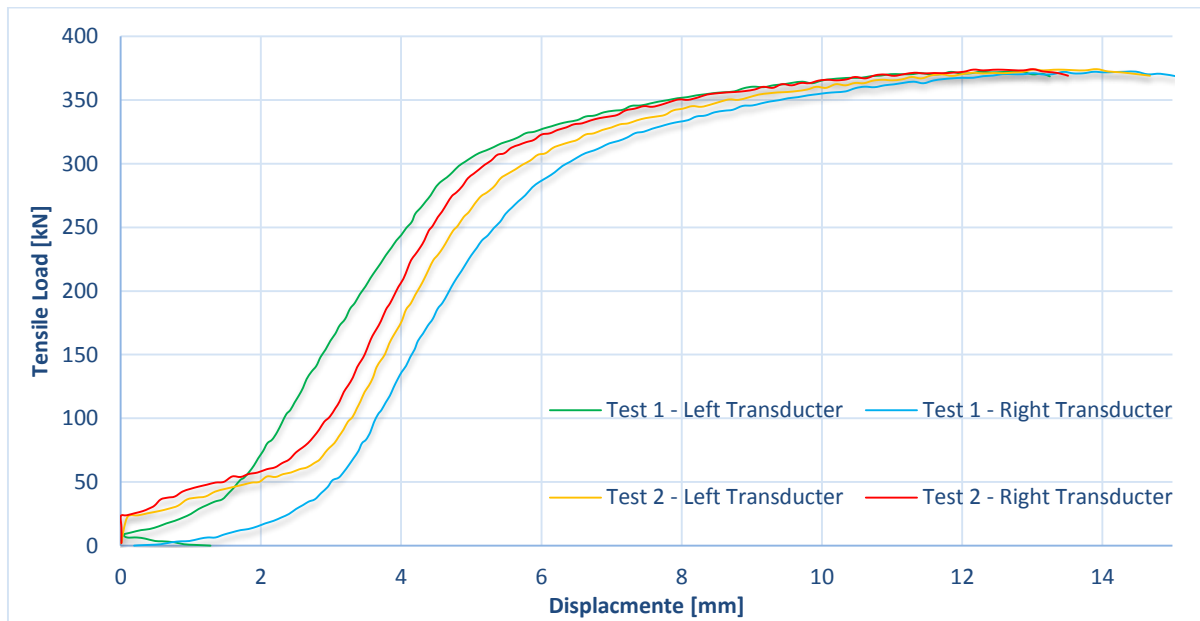

Figure 3.17 – Set 3, Plate tearing test (Countersunk M16)

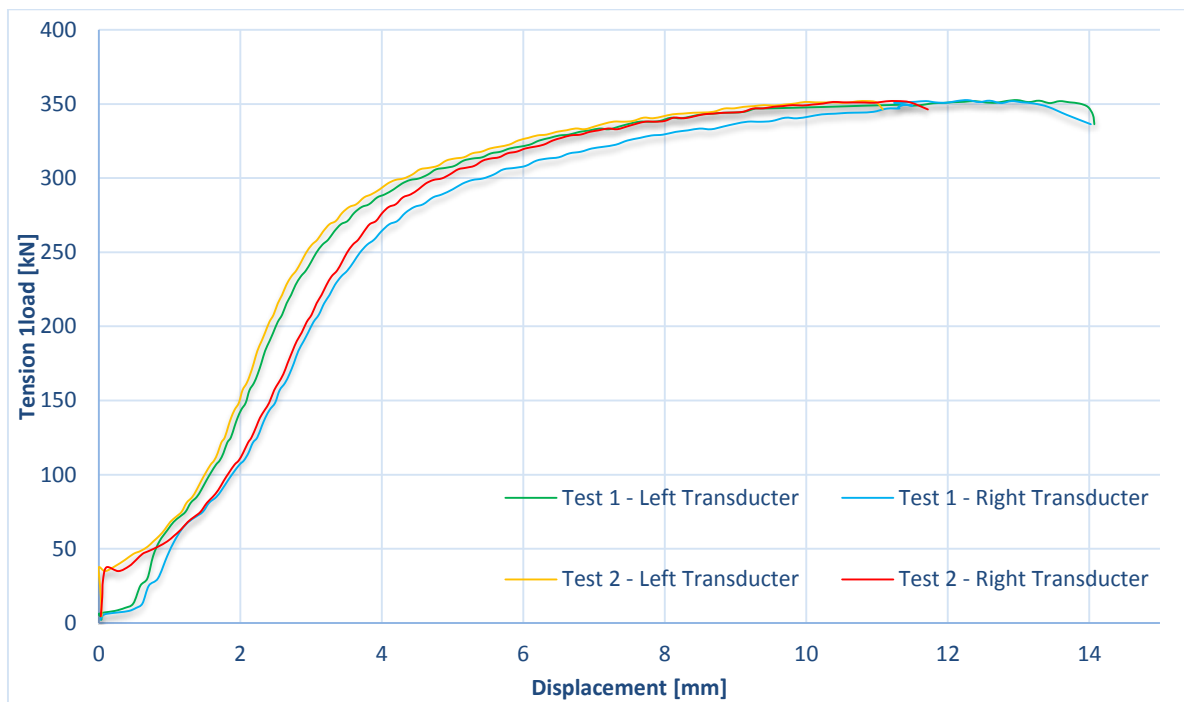

Figure 3.18 – Set 4, Plate tearing test (Socket Head M16)

In all tests, the curve starts with low inclination representing the minor adjustments and elimination of the corresponding gaps in the system. After this, the curves present a steeper linear behavior representing the elastic phase that ends at the yield resistance, followed by a nonlinear behavior with higher displacements for smaller strength increments, characteristic of

the plastic phase that ultimately ends with the connection failure. To better understand the phenomena please refer to Figure 3.19, depicting the strength-displacement of the M12 countersunk test.

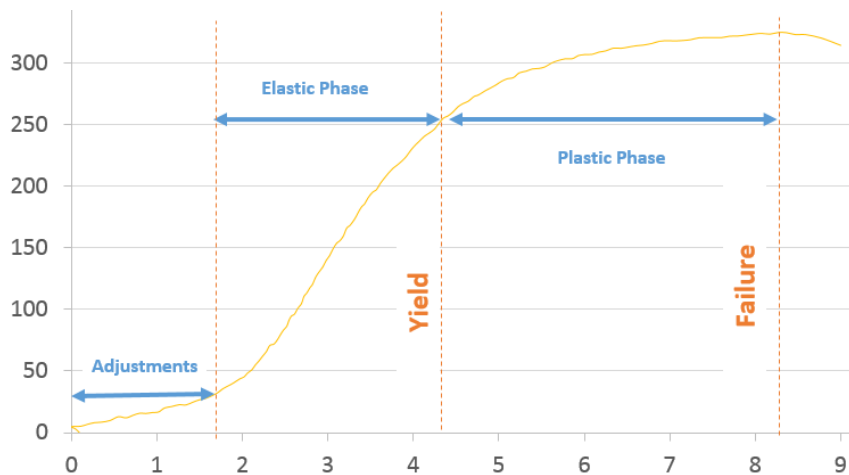

Figure 3.19 - Tension-displacement curve phases

As previously referred only 2 tests with the same components were produced, an important aspect is that, in all sets, the failure occurs for the same values. It's also observable differences regarding the displacements transducers data that stabilize after the adjustments are complete, this eccentricities are not considered enough to jeopardize the expected behavior.

The difference between countersunk and socket head bolts curves, leads to the conclusion that socket head bolts offer a higher stiffness to the connection due to the prying effect induced by their head geometry.

Another important observation is the overall displacement of the shear bolt. The displacement reaches values of 8 to 10 mm. Comparing them to displacements attained in the sets that failed by plastic yield of the inner plates, displacements with values around 14mm, it's possible to conclude that the second form of failure presents a higher ductility and therefore more advisable from a structural design point of view.

The overall displacement can be observed in Figure 3.20, it is easy to see a relatively pronounced displacement after the test specimen with the M16 socket head bolts and 6 mm thickness plate reaches its ultimate resistance.

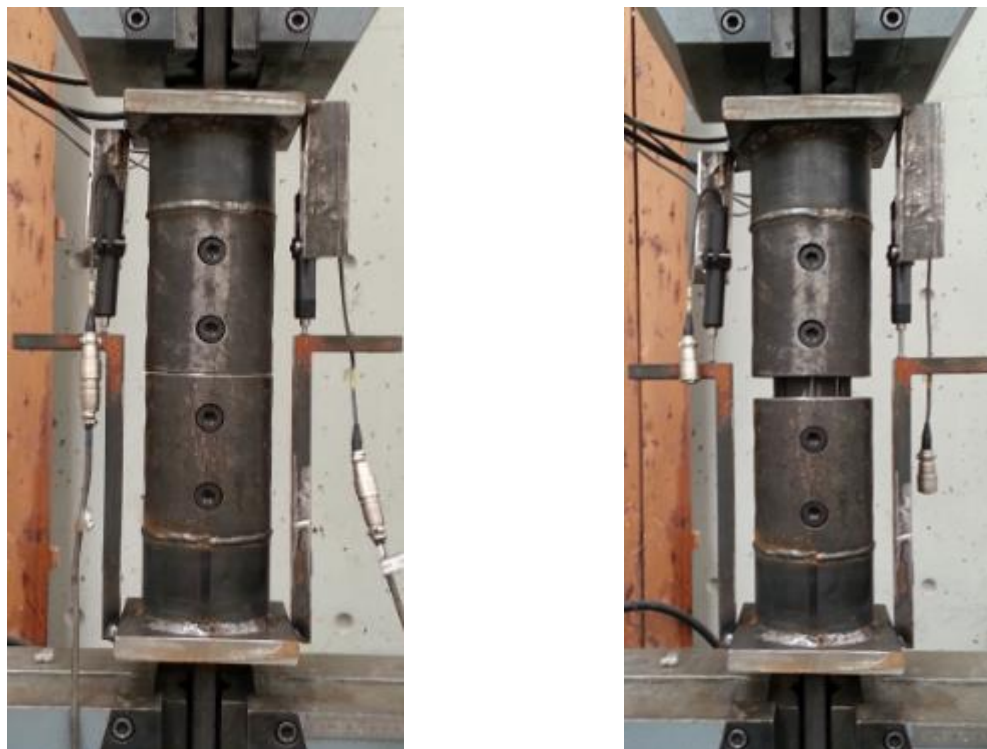

a) Pre test

b) Post test

Figure 3.20 - Plate tearing test deformation with M16 socket head bolts

3.5.4 Extensometers data

The data from by the extensometers is presented in the following graphics (Figure 3.22) that relate force (y axis) with strains (x axis, in percentage) the data is grouped by extensometers position. Figure 3.21 serves as a reminder for the extensometers location. Some extensometers are not reported due to malfunction.

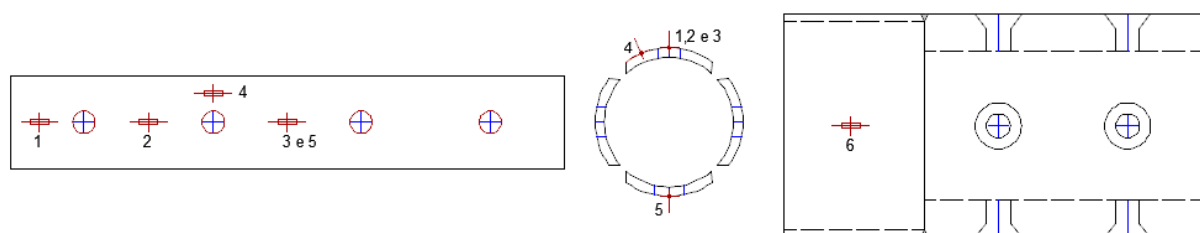

Figure 3.21 - Extensometers position

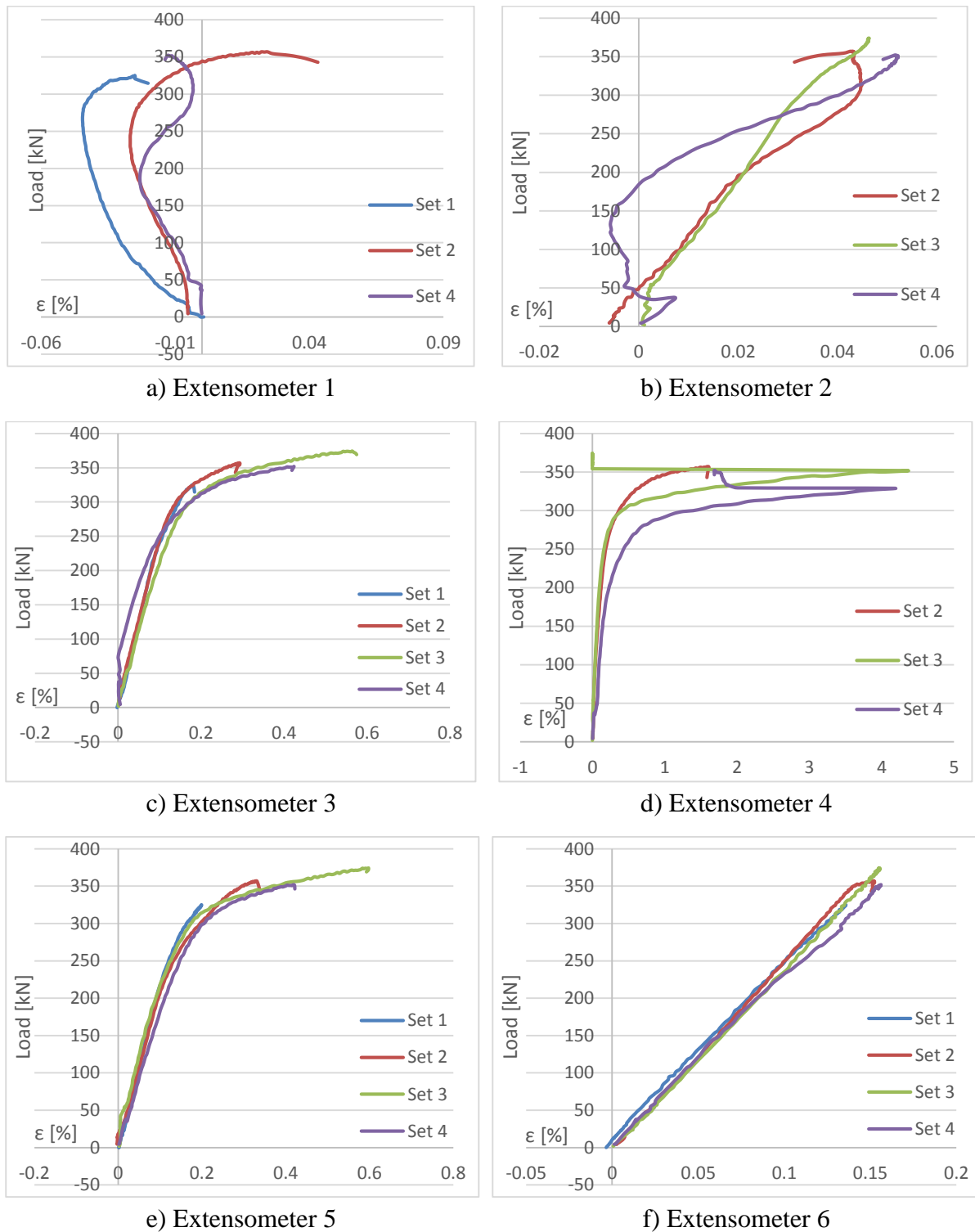

Figure 3.22 – Load-Strain curves

It's important to refer that the previous graphs do not have the same axis scales.

By analyzing the results it's possible to observe that the extensometers located at position 3 and 5 have very similar development, this is expected as they are in diametrical opposed positions confirming the inexistence of relevant eccentricities in the loading and behavior. As anticipated, the extensometers in position 1 are subjected to compression, and its compression tends to increase more noticeably for higher strengths due to the elongation of the bolts holes. As for the position 2, its strain tends to increase proportionally with the strength for shear bolt tests, but for plate tearing tests the curves tend to have a more unstable behavior due to the holes elongation being more pronounced and this extensometers being located in the middle of two holes that on one side are crushed and on the other are stretched.

By comparing the results in position 3 and 2, the position 2 has less strains than position 3. The force transfer occurs through the plates and then to the bolts followed by the outer tube, the inner bolt transmits part of that force, hence reducing the stress that reached the position 2.

As for position 4, the lower cross-section area leads to increased strains and stresses, which ultimately lead to the connection failure in plate tearing tests. The impact of the lower cross section area is confirmed when, in the same position, bolt shear tests present lower strains for higher strength because bigger bolt diameter leads to lesser cross section area. The expected strains and force is higher than the obtained values, but due to the extensometers limitations the values don't exceed the 4% strain.

In positions 3 and 5 it's possible to observe that for bolt shear tests the inner plates don't reach a plastic phase as opposed for the plate bearing test. Position 6 data presents a clear linear curve very similar in all tests depicting the lack of the influence that the connection's behavior has on the structural elements.

4 NUMERIC PROCEDURE

4.1 Introduction

As it is well known, the increase of computational power has provided powerful tools of analysis, one of them is the numerical analysis using the method of finite elements. Although the use of finite element method is a growing trend, it is a relatively new design method lacking the proper norms, the Eurocode do not address this method in particular but only references it in EC3-1-5, Annex C, structural design using the finite element method (FEM) must not be taken lightly due to its complexity and difficulty to master.

The different aspects present in the case study, lead to a certain degree of complexity regarding the joint modeling, particularly the contact between the different components. Other aspects that need to be present throughout the modeling process are the joint geometry, the materials constitutive laws, boundary conditions, load conditions and non-linear behavior (geometric and material).

To proper model the connection's three-dimensional behavior there are two element types to choose from, the shell element or solid element. Shell elements can simulate collapse behavior in a three-dimensional manner, but can't reproduce the contact interactions such as the contact between plate and bolt. To overcome this issue the solid element was chosen, since it offers a correct simulation (Coelho, 2004).

4.2 Geometry

The present modeling aims to accurately represent the physical phenomena happening throughout the experimental procedure, with this in mind the model's geometry is the one described in the Chapter 3 with the difference of being only a fourth of the real joint in order to have an expediter calculation, see Figure 4.1. The hollow section and the outer tube are considered a single piece. Regarding the bolt models the diameter was reduced to the equivalent shear diameter to properly simulate the threaded shear plane resistance, by reducing the bolt's diameter the hole must be adjusted with it in order to prevent an unrealistic bolt-hole gap that would enable the bolt to tilt. One might argue that the thread's crest will crush when the bolt is submitted to shear and therefore the bolt-hole gap should take that into account, this possibility was disregard after observing the intact crest of sheared bolts, as in Figure 3.13.

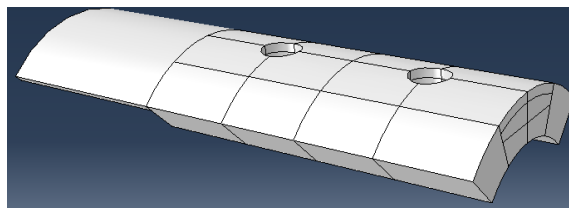

a) M12 socket head bolt outer component

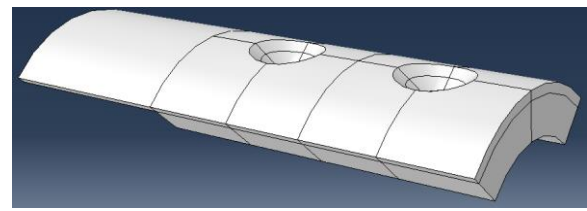

b) M12 countersunk bolt outer component

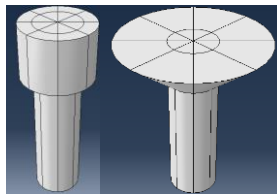

c) Socket head bolt and countersunk bolt

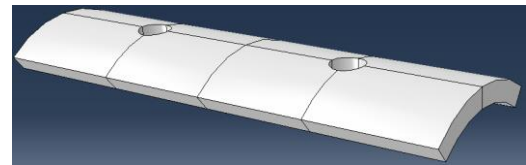

d) Inner plate for M12 bolts

Figure 4.1 - Shear bolt model's components

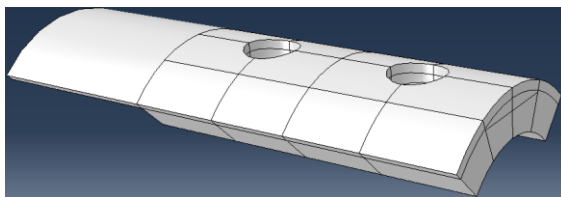

a) M12 socket head bolt outer component

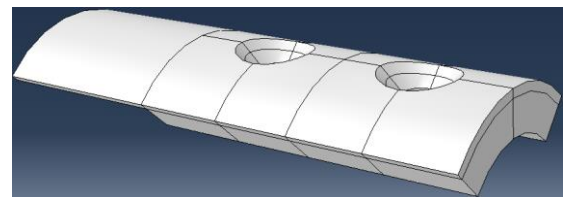

b) M12 countersunk bolt outer component

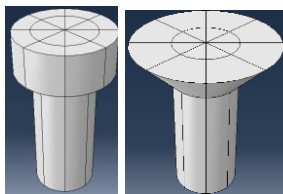

c) Socket head bolt and countersunk bolt

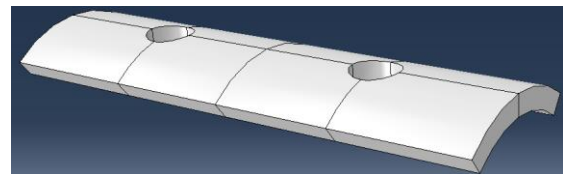

d) Inner plate for M12 bolts

Figure 4.2 - Plate tearing model's component

4.3 Support and load conditions

Since the model is a fourth of the actual connection, it's necessary to define the boundary conditions affect to the surfaces that supposedly have continuity and the external supports.

To simulate this continuity the nodes contained in the referred surfaces, are restricted in the directions that are orthogonal to the connections longitudinal axis. The hollow section's surface is fixed lengthwise. To simulate the applied loading, the inner plate is pulled, this is achieved by applying a longitudinal displacement to the nodes section's plate surface, see Figure 4.3.

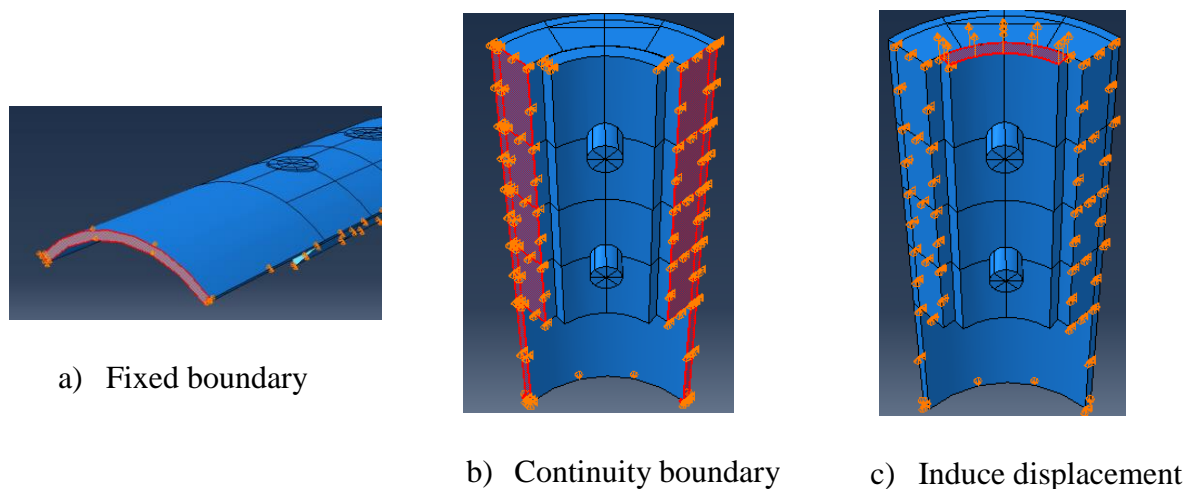

Figure 4.3 - Boundary condition

4.4 Element

The software chosen to model the present study is Abaqus, having an extensive element library to address different types of problems, its necessary to choose the one that offers the best solution by analyzing the 5 different aspects that influence how the element behaves (Tu-Chemnitz@, 2014):

- Family;
- Degrees of freedom;
- Number of nodes;
- Formulation;
- Integration.

Element's family are differentiated through geometry, the Figure 4.4 shows the most common geometries used in stress analysis, such has the subject of this thesis.

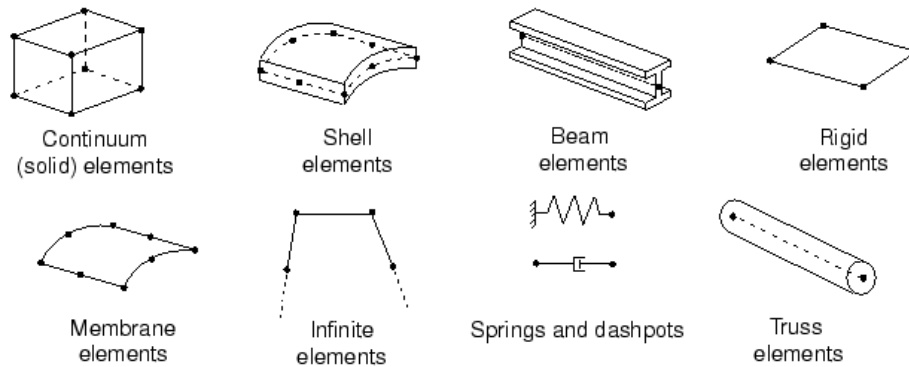

Figure 4.4 - Element family (Tu-Chemnitz@, 2014)

Degrees of freedom (DOF) are fundamental variables that are calculated during the analysis. For a stress/displacement simulation the elements have no rotational degrees of freedom on the nodes, the internal displacement field is defined in terms of nodal displacements only, such as the solid elements. The referred displacements are calculated at each node of an element, the displacement at any other point of the referred element, it's obtain by interpolating the nodes displacements. The interpolation order is determined by the number of element's nodes as illustrated in Figure 4.5. For example, the element shown in Figure 4.5- a), only has nodes at its corners and uses linear interpolation in each direction therefore being called linear element or first-order element. Different elements tend better for different specific simulations, for non-linear problems involving plastic contact phenomena, the 8 node bricks can represent better the discontinuities and strain fields at the element boundaries, thus improving the numerical results (Coelho, 2004).

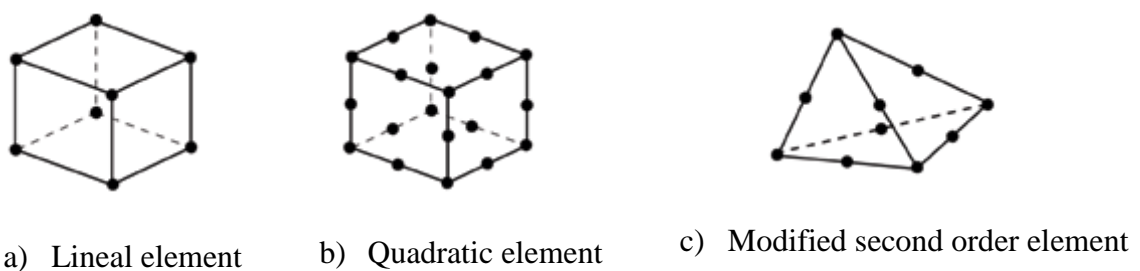

Figure 4.5 - Linear brick, quadratic brick and modified tetrahedral elements

The formulation of an element refers to the mathematical theory behind the definition of its behavior. Knowing that there are no adaptive meshing in this study, there are two possible mathematical theories, the Eulerian and the Lagrangian. In the Lagrangian or material description behavior, the matter associated to an element remains associated to this element throughout the simulation, it cannot flow across the element boundaries. The Eulerian formulation is the

opposite, since it's the elements that are fixed in space as the matter flows between them, used in thermodynamics and fluid mechanics simulations.

Through numerical techniques various quantities over the volume of each element can be integrated. Using Gauss quadrature the material response to each integration point in each element can be evaluated, the integration can be full or reduced, a choice that can have a significant effect on the accuracy of the element. The difference between the possible integrations rests on the different amount of Gauss points required to integrate the polynomial terms in an element's stiffness matrix, as the example observed in Figure 4.6 of a quadratic element. Linear reduced-integration elements can give acceptable results as long as a reasonably fine mesh is used.

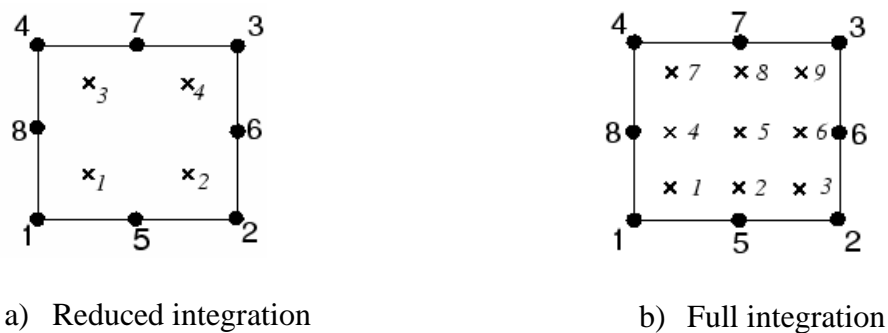

Figure 4.6 - Gauss integration points for a quadratic element

Regarding the element size, a model must have a mesh sufficiently refined to produce accurate results, but must also take into account an adequate calculation time. To obtain reliable simulation's results the perimeter of the bolt and hole must have at least 24 nodes, the plates must also have 4 or more layers of solid elements through their thickness (Vegte, 2004), thus providing a reasonably fine mesh enabling a linear reduced-integration, decreasing the calculation time. In Figure 4.7, a mesh example can be seen where only 2 layers of solid elements in the inner plate is presented.

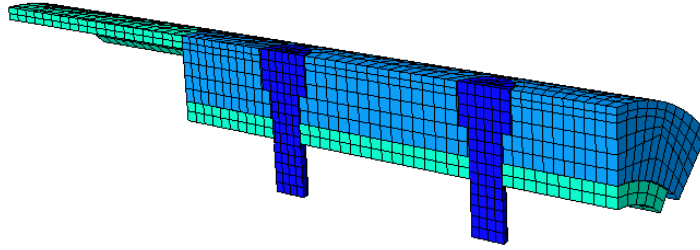

Figure 4.7 - Mesh example in sectioned model

Attending to all the considerations in this Chapter 4, the element chosen for the simulation is the C3D8R. It's a solid hexahedral element with 8 nodes, each node has 3 degrees of freedom (u , v and w), and it also presents a 2x2 Gauss points for reduced integration. The non-linear geometry is taken into account by using the Lagrangean formulation, as for the materials' non-linearity the behavior is modeled through the elasto-plastic constitutive laws of the material.

4.5 Material properties

For a proper simulation, the materials of the components must be properly defined and must be representative of the tests subjects. The material properties for the hollow section's steel and bolt's steel are both the same: isotropic with elasto-plastic behavior, 0.3 for Poisson's ratio (ν) and 210GPa for the elasticity module (E) (Simões da Silva *et al*, 2007). Lacking tension test describing the mechanical behavior of the different steel grades, nominal values were used with 5% extension in failure, see Table 4.1 - True stress and true strain used in model.

When defining plastic behavior, Abaqus requires true stress and true strain in order to interpret correctly the data, this is obtained using the following formulation and presented in Table 4.1, the different materials assigned to the different components can be seen in Figure 4.8.

$$\sigma_{true} = \sigma_{nom} (1 + \varepsilon_{nom}) \quad (5)$$

$$\varepsilon_{true} = \ln(1 + \varepsilon_{nom}) \quad (6)$$

$$\varepsilon_{true,pl} = \varepsilon_{true} - \frac{\sigma_{true}}{E} \quad (7)$$

Table 4.1 - True stress and true strain used in model

Classe 8.8		Classe 10.9	
Yield True Stress [kN]	Plastic True Strain	Yield True Stress [kN]	Plastic True Strain
672	0.045590164	945	0.044290164
840	0.044790164	1050	0.043790164
864	0.072846755	1080	0.071818184
Steel S275		Steel S355	
Yield True Stress [kN]	Plastic True Strain	Yield True Stress [kN]	Plastic True Strain
288.75	0.047415164	372.75	0.047015164
451.5	0.046640164	451.5	0.046640164
464.4	0.074749613	464.4	0.074749613

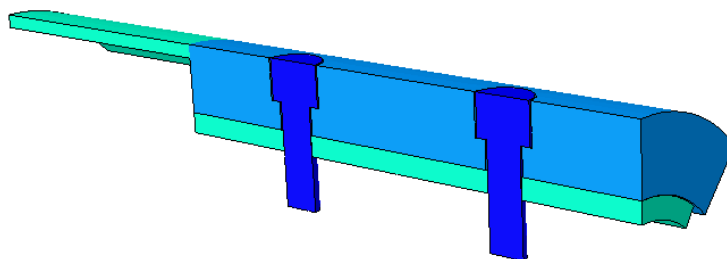

Figure 4.8 – Material properties assignment

4.6 Interaction and contact

The connection's model in study is composed of three different components, the interaction between them is simulated by defining the contact's properties of each type of contact. Two types of contact were considered, the simple interaction between plane steel surfaces (e.g. outer tube with inner plate) and the more complex interaction between threaded surfaces. The interaction between the bolt and inner surface of the outer tube holes is considered a plane contact, the contact interactions can be seen in Figure 4.9.

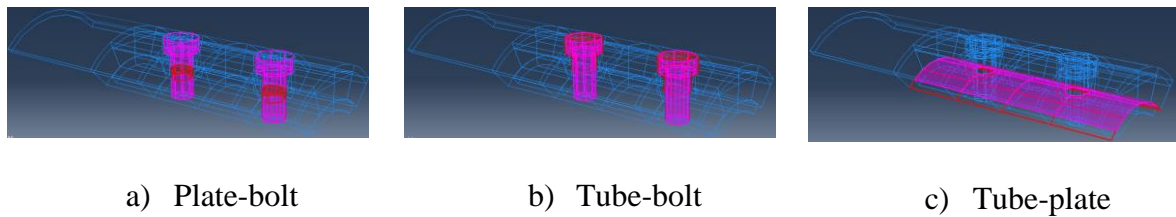

Figure 4.9 - Interactions considered

The plane interaction is divided in its tangential and normal direction. The normal direction is defined as “hard contact” ensuring that there will be no overclosure of the material, the tangential component has a 0.1 friction coefficient (Freitas, 2013). Both components are defined as “penalty” ensuring that the interaction can only be taken into account if the surfaces are, in fact, in contact. The threaded contact is more complex to simulate, it enables normal relative displacements but restrains tangential relative displacements (bolt lengthwise only), the first approach was to simulate this exact behavior but the software wasn’t able to converge its calculations due to the fact that the bolt lacked proper external restraint, this happened because the normal contact freedom enabled the bolt to wobble in its hole (in spite of the zero clearance). To counter this issue, the bolt was tied to the hole in a manner that allowed the hole to stretch (characteristic bearing deformation), as shown in Figure 4.10. The thread detail is not necessary to model since it’s complex, time consuming and does not improve the results significantly (Williams et al, 2009).

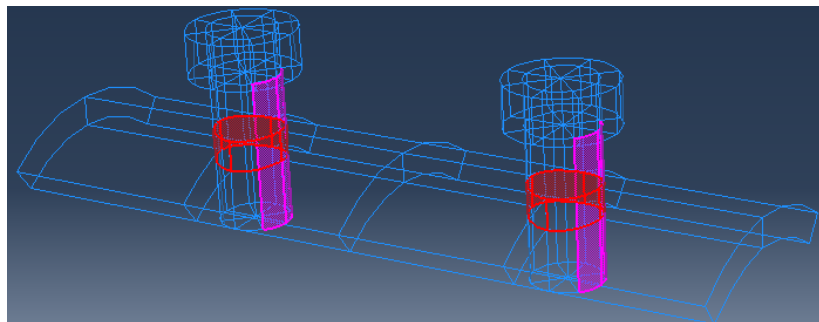

Figure 4.10 - Tie definition between bolt and plate

4.7 Results analysis and comparison

As previously referred the most important characteristic that describes the connection behavior is the curve that relates force with displacement, obtained by summing the support reaction in the nodes contained in the structural hollow sections surface and relating them with the imposed displacement. To simplify the following graphs, the curves obtained in the experimental analysis are displayed in average values for any given set. The recommendation made by Vegte

about the 4 layer of solid elements in plates was tested on the countersunk M12 (bolt shear) model, comparing a model with 4 layers on the inner plate to a model with only 2 layers, by observing Figure 4.11 the 2 layer model adjust better to the experimental behavior, hence the use of only 2 layers in the following model, reducing also the calculation time.

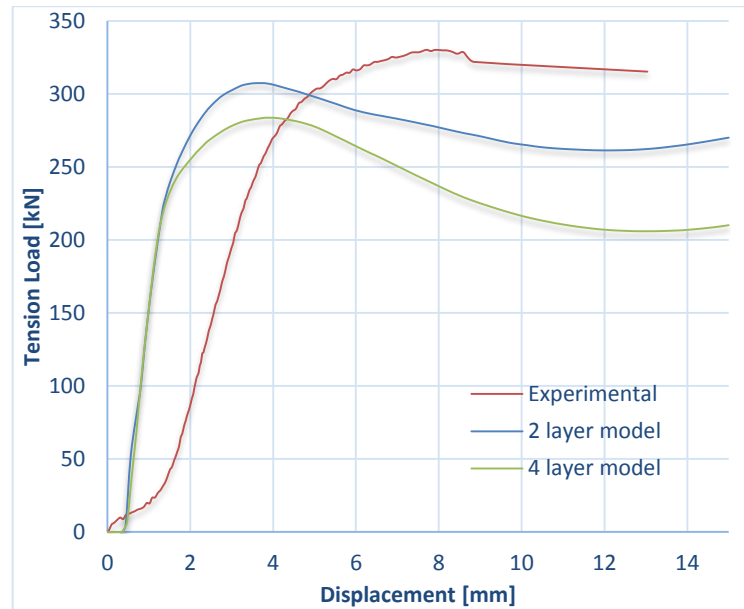

Figure 4.11 – Countersunk shear bolt plate's layers comparison

For a better comparison, understanding and critical assessment of the models' quality in representing the phenomena occurring during the tests, the following graphs present in Figure 4.12, Figure 4.13, Figure 4.14 and Figure 4.15 contains the experimental curve and the numerical modeling curve.

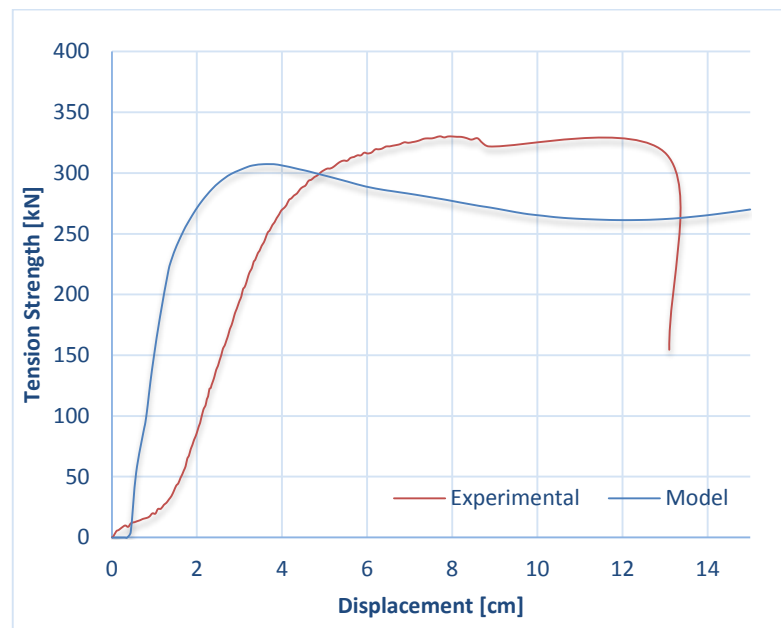

Figure 4.12 – Set 1, bolt shear test and model (M12 countersunk bolt)

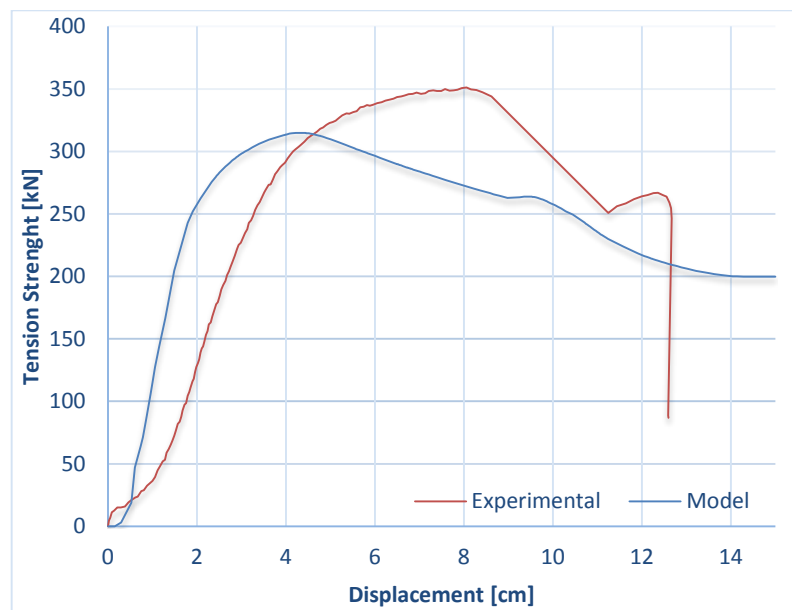

Figure 4.13 - Set 2, bolt shear test and model (M12 socket head bolt)

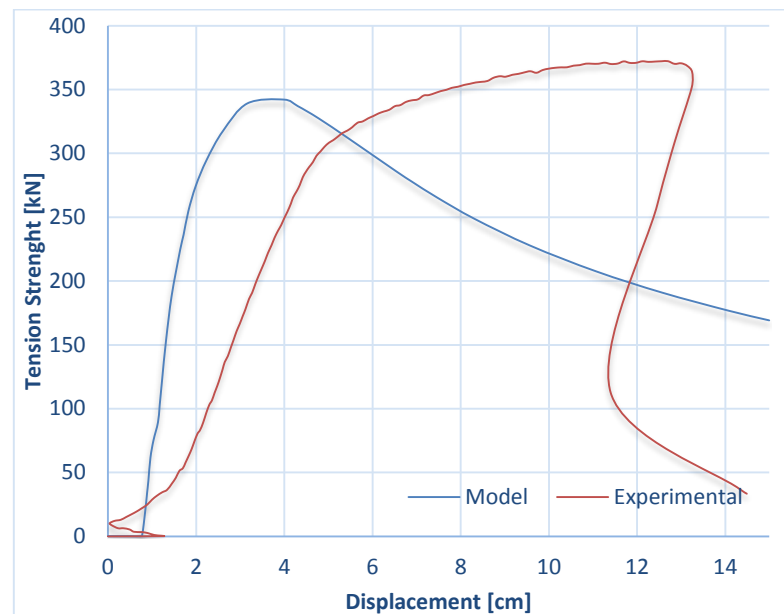

Figure 4.14 - Set 3, plate tearing test and model (M16 countersunk bolt)

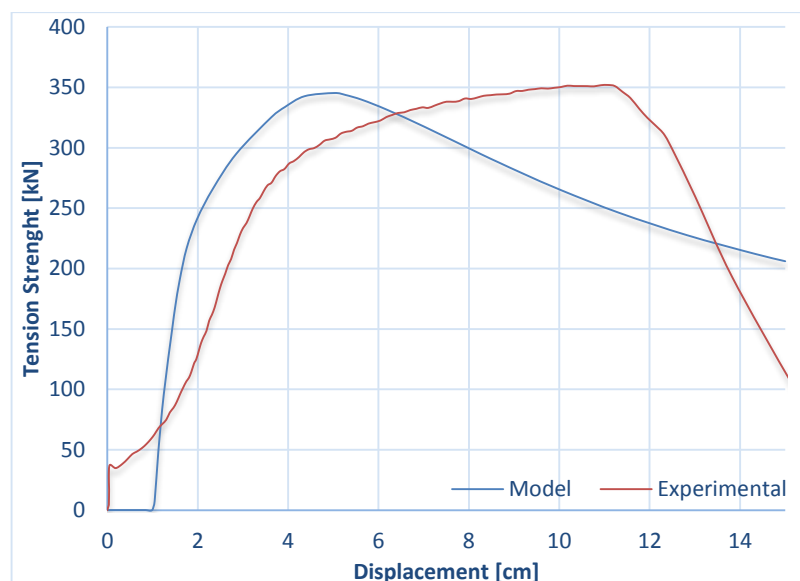

Figure 4.15 - Set 4, plate tearing test and model (M16 socket head bolt)

In all models it's possible to observe the same phases mentioned in the experimental analysis: the adjustment phase, with flat development; the elastic phase, presenting a linear and steeper curve; and lastly, a plastic phase, that as a smaller development. The smaller plastic development is due to the fact that the model is more linear than the experimental test where its different components achieve plastic state at different rates extending the plastic phase.

When a steel batch is produced, it is classified according to its resistance on the safe side, this means that a steel with 300MPa yield resistance is classified to the next lower steel grade, in this case S275 steel. Bearing this in mind, the nominal mechanical proprieties used in the modulation have inferior resistance then the steels real resistance, justifying the lower resistance in all models relatively to the experimental tests. This difference is less significant in the plate tearing models due to the fact that the equivalent diameter used in the inner plate's hole increases the area of cross section where the tearing happens therefore increasing the resistance, see Figure 4.16, this is not relevant in the shear bolt models because the failure mode occurs in the bolts.

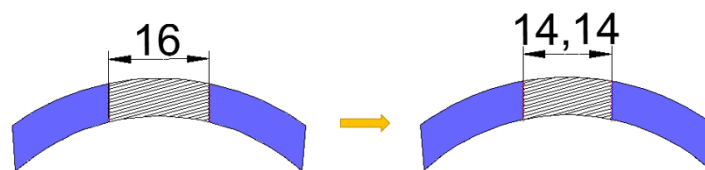

Figure 4.16 – Tearing area increase, in the left real diameter, in the right equivalente diameter (mm)

In spite the experimental and numerical resistances present similar values, the displacements and consequently the initial stiffness are not correctly modelled, this is due to the nominal values not recreating properly the plastic behavior of the used material.

To demonstrate the evolution of stresses inside the components 3 different states are taken into account: i) elastic state, ii) plastic state and iii) rupture. Each of this states were studied through the von Mises equivalent stress that combine the present stress state and shows the direction which the maximum stress follows. Figure 4.17, Figure 4.18, Figure 4.19 and Figure 4.20, show the von Mises stress throughout the modeling. The stresses obtained in the modeling are in accordance with expected results and strains measured in the experimental procedure. The exception is the already discussed readings obtained for the mid hole extensometer position.

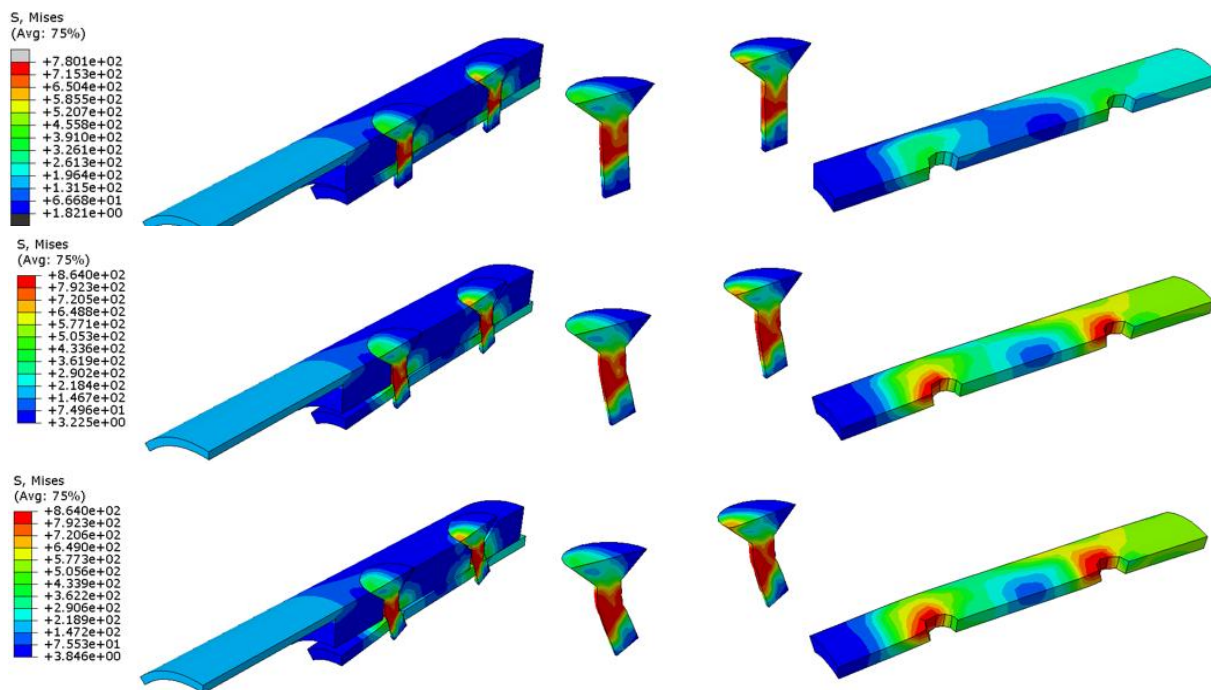

Figure 4.17 - Set 1, countersunk shear bolt (top to bottom: elastic, plastic, failure)

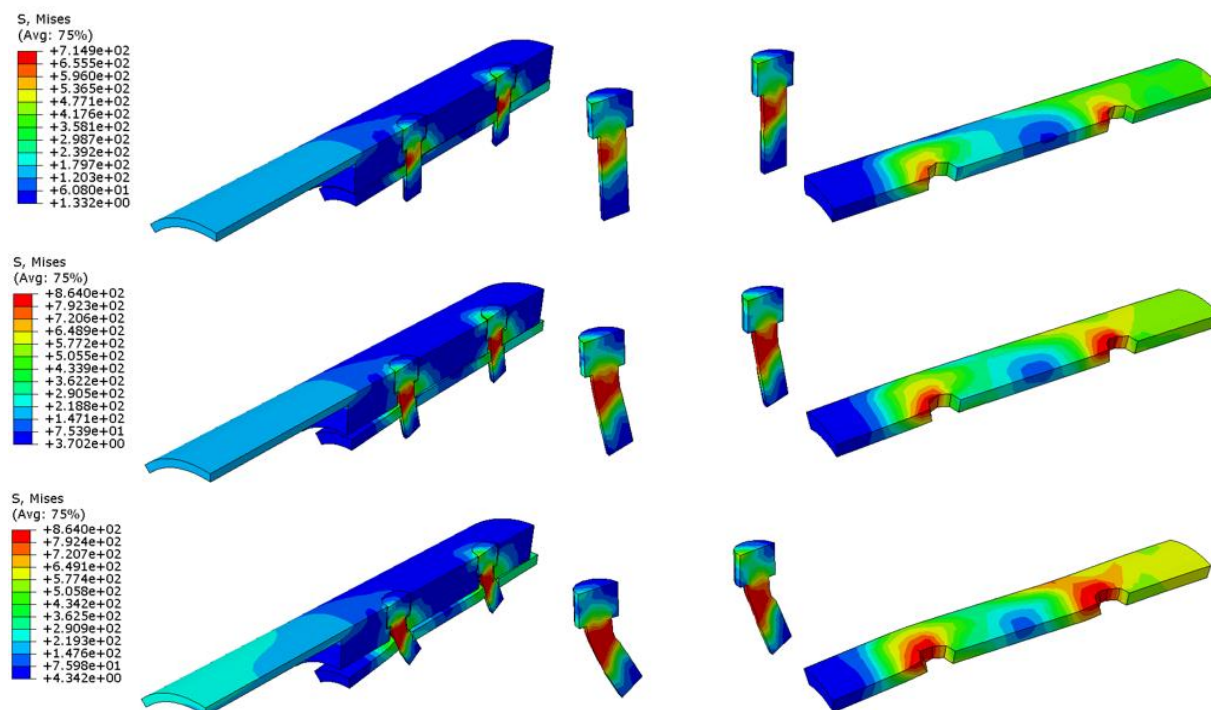

Figure 4.18 - Set 2, socket head shear bolt (top to bottom: elastic, plastic, failure)

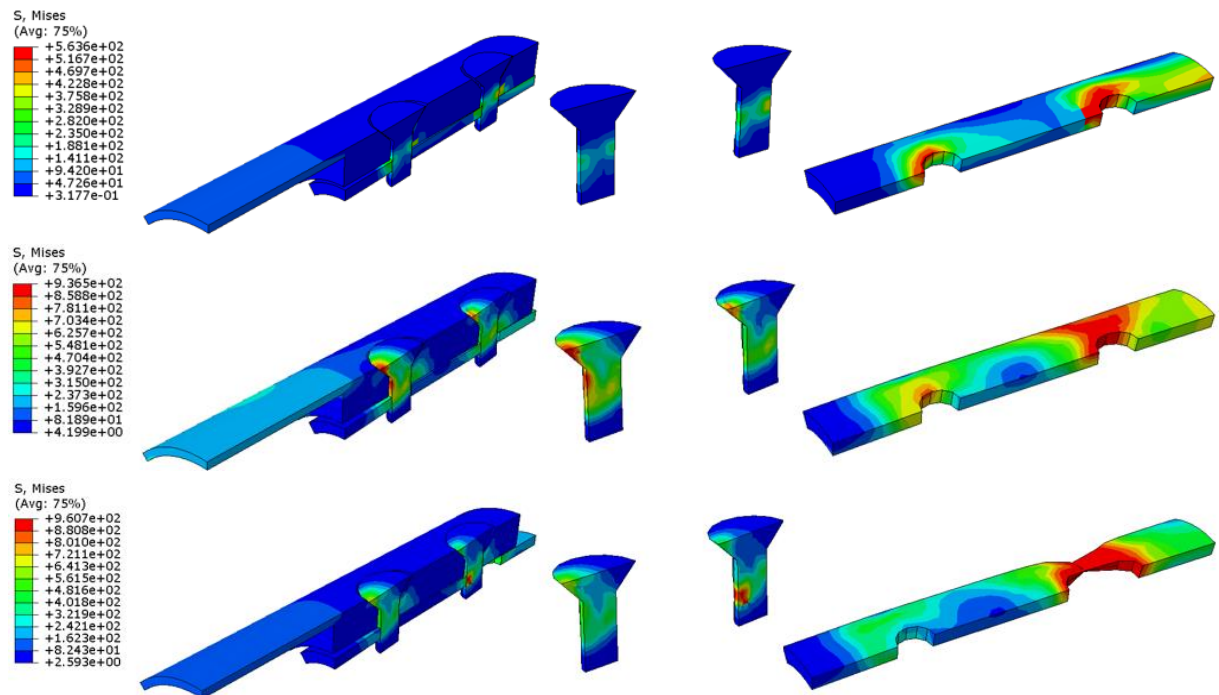

Figure 4.19 - Set 3, countersunk bolt plate tearing (top to bottom: elastic, plastic, failure)

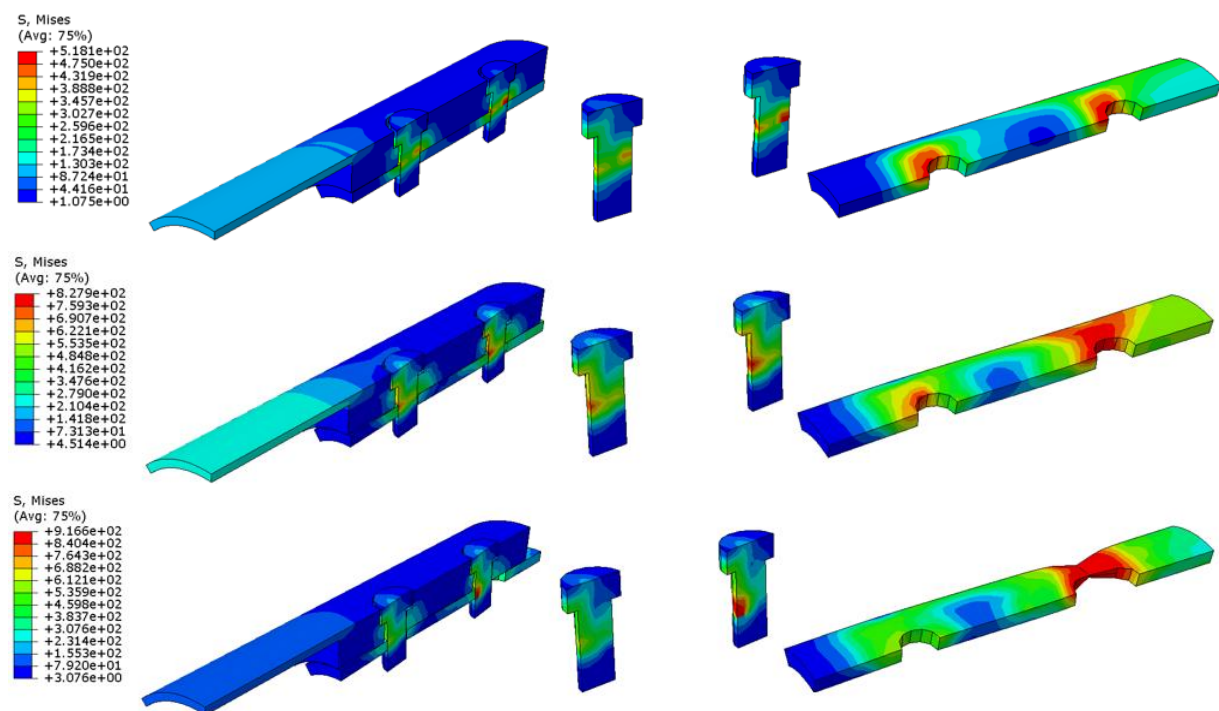

Figure 4.20 - Set 4, socket head bolt plate tearing (top to bottom: elastic, plastic, failure)

5 ANALITIC PROCEDURE

5.1 Introduction

The calculations in the analytic procedure follow the formulas predicted in the Eurocode 3, Part 1-1 and Part 1-8. Due to the forces type mobilized in the joint components, the connection in study is classified as a bearing connection. However, it's necessary to be aware that the connection doesn't have a bolt nut and the elements are not flat. Although the European norms only address shear connections between flat elements, there is no distinction between plane elements or curved ones, enabling the use of the Eurocode formulas to calculate the resistances.

5.2 Bolted connection shear behavior

As the load increases the following phenomena's occur. At first the gap existing between bolts and the hole surface is eliminated, after this adjust the stresses between them start to manifest (like plate bearing stress and bolt shear stress), this will induce increasingly high tensions in the connection components. The failure proceeds to occur in the least resistance way (or a combination of them), it can occur by bolt shear, tearing plate, plate bearing or even plate shear as shown in Figure 5.1.

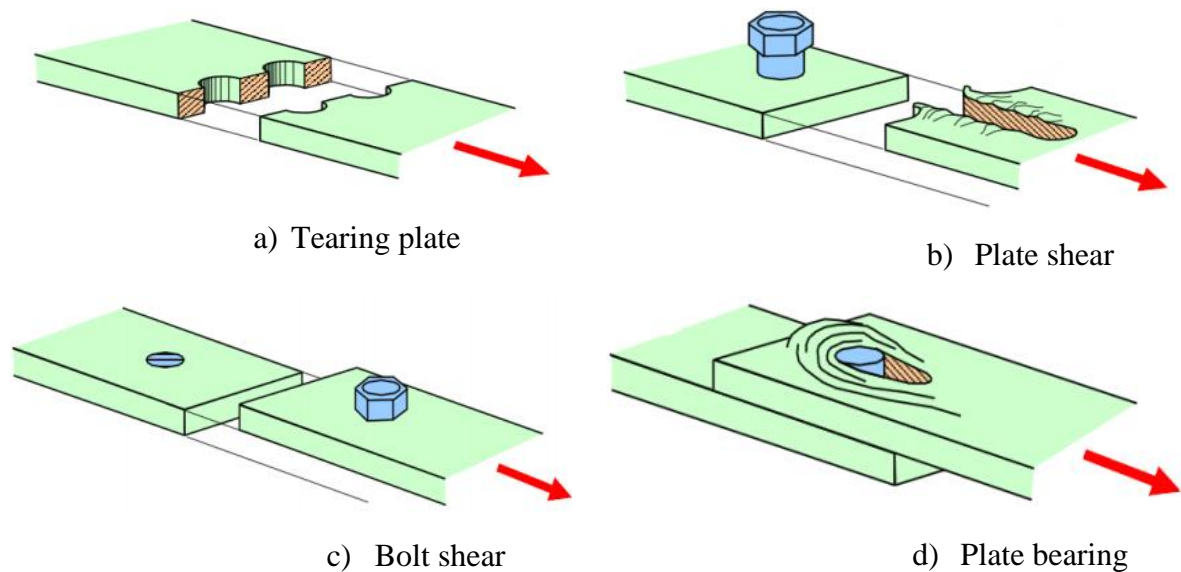

Figure 5.1 - Failure modes in a shear connection (Soares, 2012)

5.3 Formulation predicted in Eurocode 3, Part 1-8 for bearing connections

According to the Eurocode the following verifications are needed in order to verify the resistance of a conventional bearing connection:

- Bolt submitted to shear;
- Block tearing (or net cross section tearing);
- Plate bearing;
- Tensioned section;
- Weld resistance (not needed in the present connection).

The weld resistance is not verified because it's a full penetration weld with a broad throat thickness, therefore the resistance will be considerably higher than the other components. As for the block tearing it's not analyzed in the outer tube, due to the high thickness the resistance to this failure mode is expectedly higher than the others modes.

In a bolted connection the holes need to be properly spaced between other holes and to the plate extremities. The minimum limits are defined in Eurocode 3, Parte 1-8 clause 3.5, attending Figure 5.2 this limits can be calculated using the equations 5, 6 e 7.

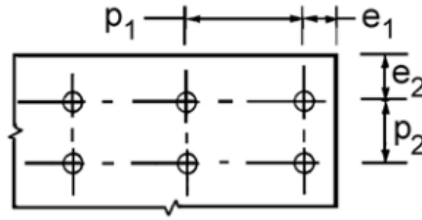

Figure 5.2 - Symbols for spacing of fasteners

$$e_1 = e_2 = 1.2 \cdot d_0 \quad (8)$$

$$p_1 = 2.2 \cdot d_0 \quad (9)$$

$$p_2 = 2.4 \cdot d_0 \quad (10)$$

Being d_0 the hole's diameter.

The overall connection resistance is determined by the least resistant component, through Table 3.4 present in clause 3.6.1 of the already mentioned Eurocode, Part 1-8 and Part 1-1 clause 6.2.3 (plate tearing), it's possible to determine each resistance using the following formulation:

- Bolt shear resistance, $F_{v,Rd}$:

$$F_{v,Rd} = \frac{\alpha_v \cdot f_{ub} \cdot A_s}{\gamma_{M2}} \quad (11)$$

Taking into account:

α_v is a reduction factor defined in EC3 1-8, Table 3.4;

f_{ub} is the ultimate tensile strength of a bolt;

γ_{M2} is the partial safety factor;

A_s is the tensile stress area of the bolt measured on the threaded portion.

- Plate bearing resistance, $F_{b,Rd}$:

$$F_{v,Rd} = \frac{k_1 \cdot \alpha_b \cdot f_u \cdot d \cdot t}{\gamma_{M2}} \quad (12)$$

Taking into account:

k_1 is a reduction factor defined in EC3 1-8, Table 3.4;

α_b is a reduction factor defined in EC3 1-8, Table 3.4;

f_u is the ultimate tensile strength of the steel plate;

d is the nominal bolt diameter;

t is the plate thickness;

γ_{M2} is the partial safety factor.

- Section tension resistance, $N_{pl,Rd}$:

$$N_{pl,Rd} = \frac{A \cdot f_y}{\gamma_{M0}} \quad (13)$$

Taking into account:

A is the gross cross-section area;

f_y is the yield tensile strength of the steel plate;

γ_{M0} is the partial safety factor.

- Plate tearing resistance, $N_{u,Rd}$:

$$N_{u,Rd} = \frac{0.9 \cdot A_{net} \cdot f_u}{\gamma_{M2}} \quad (14)$$

Taking into account:

A_{nt} is the tensioned cross-section area;

f_u is the ultimate tensile strength of the plate steel;

γ_{M2} is the partial safety factor.

5.4 Results and comparison with previous methods

The analytic results of the previous formulation with nominal resistances and safety factors of 1 for the test sets can be consulted in the following Table 5.1, as expected, the weaker components are the ones that present limit the connection's resistance.

Table 5.1 – Analytical results

	Set 1 and 2	Set 3 and 4
Components	M12 bolt and 6mm thick plate	M16 bolt and 6mm thick plate
Shear bolt [kN]	323.71	628.00
Plate bearing [kN]	476.31	401.59
Plate tearing [kN]	368.17	333.07
Section tension [kN]	400.87	400.87

To better conclude the analysis that were made, the results between procedures were grouped in Table 5.2, they are compared with the help of a ratio that correlates the numerical and analytic result with the experimental data.

Table 5.2 – Synthesis table

	Set 1	Set 2	Set 3	Set 4
Components	M12 countersunk bolt, 6mm thickness plate	M12 socket head bolt, 6mm thickness plate	M16 countersunk bolt, 6mm thickness plate	M16 socket head bolt, 6mm thickness plate
Experimental [kN]	330.17	351.12	370.55	351.08
Numerical [kN]	307.30	314.89	342.03	345.36
ratio	0.93	0.89	0.92	0.98
Analytical [kN]	323.71	323.71	333.07	333.07
ratio	0.98	0.92	0.89	0.94

The results state that all procedures produced similar results with a low percentage of error (not superior to 11%) and more important to observe is that the numerical and analytical procedures are able to make a low error prediction on the safe side.

It's possible to conclude that it's feasible to achieve the structural elements resistance by increasing the inner plate's resistance, ensuring this way that this connections is, in fact, able to withstand forces superior to the ones that the element that it is splicing can endure.

6 CONCLUSIONS AND FUTURE DEVELOPMENTS

6.1 Conclusions

The objective of this thesis was the experimental, numerical and analytic analysis of a new type of splice connection between circular hollow sections used in truss structures. The evaluation of the connections performance provided the following conclusions:

- Increasing the outer tube thickness prevents the bolts rotation around an axis perpendicular to the bolts longitudinal axis, ensuring a clean cut behavior of the bolt and bearing of the plates;
- The prying effect provided by the socket head bolt's head provides a small increase of the connection stiffness;
- To calculate bolted connections submitted to shear forces the formulation provided by the European norms are able to predict with reduced error the connections resistance;
- Finite element method can be used to model the connection and conduct a parametric study;
- The studied configuration is a high performance connection with a possible resistance superior to the structural element that is splicing, combined with a dissimulated appearance.

6.2 Future developments

The suggested future developments are:

- Produce material characterization tests and apply the data to the existing numerical models, refining and calibrating them;
- Vary the outer tube's thickness to analyze its importance in the bolts rotation;
- Increase the inner plates resistance to ensure failure in the structural tube;
- Perform a parametric study varying thicknesses, bolt diameters, holes spacing, number of bolts and steel classes;
- Complete the 3D modeling to represent the complete connection;
- Scale up the magnitude of the connections and observe if the behavior maintains predictable;

- Study other possibilities for the connection, such as columns splice connections that have more than just axial force;
- Test other types of hollow sections, such as square or rectangular hollow sections.

7 REFERENCES

Carvalho, A (2012). “Avaliação Experimental de Configurações Inovadoras Para a Execução de Ligações de Emenda e Barras Metálicas de Secção Tubular”. Masters Dissertation, Departamento de Engenharia Civil da Universidade de Coimbra, Coimbra.

CIDECT@. <<http://www.cidect.org/en/Award/aw2003.php>> Retrieved access: 16th June 2014.

CISC@. <<http://www.cisc-icca.ca/solutions-centre/publications/publications/design/hollow-structural-section-connections-and-trusses#.U57olPldWSo>> Retrieved access: 16th June 2014.

Coelho, Ana Margarida Girão (2004). “Characterization of the Ductility of Bolted End Plate Beam-To-Column Steel Connections”. PhD thesis, Departamento de Engenharia Civil, Faculdade de Ciências e Tecnologia da Universidade de Coimbra, Coimbra.

Dias, R. (2011). “Ligações em Estruturas Trianguladas com Perfis Circulares Ocos”. Master’s thesis, Departamento de Engenharia Civil da Universidade de Coimbra, Coimbra.

Donsnotes@. <http://donsnotes.com/home_garden/fasteners.html> Retrieved access: 16th June 2014.

Dusicka, P., Lewis, G. (2009). “High strength steel bolted connections with filler plates”. *Journal of Constructional Steel Research* 66, pp. 75-84.

Dutta, D., Wardenier, J., Yeomans, N., Sakae, K., Bucak, Ö. e Packer, J. (1998). “Design Guide for fabrication, assembly and erection of hollow section structures”. CIDECT, Cologne.

Firmo, C. (2005). “Arquitetura com Perfis Tubulares – Uma nova linguagem”. Vallourec & Mannesmann Tubes, Brazil.

Freitas, P. (2013). “Configurações inovadoras de ligações de emenda de barras metálicas de secção tubular”. Master’s thesis, Departamento de Engenharia Civil da Universidade de Coimbra, Coimbra.

HISTWIN, 2009. High-strength tower in steel for wind turbines (HISTWIN). Contract No RFSR-CT-2006-00031 1 July 2006 to 30 June 2009, Final Report.

-
- Kim, J., Yoon, J.-C. and Kang, B.-S.(2007). “Finite element analysis and modeling of structure with bolted joints”. *Applied Mathematical Modeling* 31, pp. 895-911.
- Lecce, M. e Packer, J. (2002). “Pole Splices Using Stainless Steel Nails”. CIDECT Repor8F-10/2.
- LNEC@ <http://www.lnec.pt/qpe/eurocodigos/situacao_na_europa#antecedentes> Retrieved access: 16th June 2014.
- Newsledge@. <<http://www.newsledge.com/oil-prices-continue-fall-on-disappointing-eu-data-1545>> Retrieved access: 30th June 2014.
- Resende, A (2008). “Diagnóstico Numérico De Vigas Vierendeel Formadas Por Perfis Tubulares Metálicos De Seção Circular ”. Master Dissertation, Universidade Federal De Uberlândia Faculdade De Engenharia Civil, Post-Graduation Program in Civil Engineering.
- Santha Kumar e Satish Kumar, 2014@ <<http://pt.scribd.com/doc/31099794/Design-of-Steel-Structures-1-Prof-S-R-satish-Kumar-amp-Amp>> Retrieved access: 16th June 2014.
- Simões, R., Jordão, S., Freitas, P. (2013). “Avaliação do comportamento de ligações de emenda entre perfis tubulares”. IX Conference on Steel and Composite Construction & I Luzo-Brazilian Conference on Sustainable Steel Construction, 2013.
- Simões da Silva, L. e Santiago, A. (2003). “Manual de Ligações Metálicas”. CMM – Associação Portuguesa de Construção Metálica e Mista, Coimbra, Portugal.
- Simões da Silva, L., Simões, R. and Gervásio, H. (2010). “Design of Steel Structures” ECCS – European Convention for Constructional Steelwork, 1st Edition, 2010.
- Slbenfica@. <<http://www.slbenfica.pt/pt-pt/estadio/estadiodaluz.aspx>> Retrieved access: 30th June 2014.
- Soares, T. (2012). “Análise de Ligações em Perfis Tubulares com Parafusos de Cabeça Embutida”. Master’s thesis, Departamento de Engenharia Civil da Universidade de Coimbra, Coimbra.
- Steel-instag@. <<http://www.steel-insdag.org/TeachingMaterial/Chapter1.pdf>> Retrieved access: 16th June 2014.
- StudyBlue@. <<http://www.studyblue.com/notes/note/n/untitled-flashcards/deck/2524919>> Retrieved access: 16th June 2014.
-

Tarunchandel@. < <http://photos.tarunchandel.com/2010/09/atomium-geometric-figures-brussels.html>> Retrieved access: 30th June 2014.

Theguardian@. < <http://www.theguardian.com/business/2010/dec/27/2011-rollercoaster-year-ftse-100>> Retrieved access: 30th June 2014.

Tu-Chemnitz@. <http://www.tu-chemnitz.de/projekt/abq_hilfe/docs/v6.11/books/gsa/default.htm> Retrieved access: 22th June 2014.

Wardenier, J., J.A. Packer, X.-L. Zhao and G.J. van der Vegte (2010). "Hollow Sections In Structural Applications". CIDECT, Geneva, Switzerland. ISBN 978-90-72830-86-9.

Williams, J.G., Anley, R.E., Nash, D.H. e Gray, T.G.F. (2009). "Analysis of externally loaded bolted joints: Analytical, computational and experimental study". International Journal of Pressure Vessels and Piping, pp. 420-427.

Vegte, G. J. van der (2004). "Numerical simulations of bolted connections: the implicit versus the explicit approach". Connections in Steel Structures V, Amsterdam, June 3-4, 2004.