

International Journal of

STRUCTURAL STABILITY AND DYNAMICS

Volume 7 • Number 1 • March 2007

Size Effect of Welded Thin-Walled Tubular Joints

F. R. Mashiri, X.-L. Zhao, M. A. Hirt and A. Nussbaumer

 **World Scientific**

NEW JERSEY • LONDON • SINGAPORE • BEIJING • SHANGHAI • HONG KONG • TAIPEI • CHENNAI

SIZE EFFECT OF WELDED THIN-WALLED TUBULAR JOINTS

FIDELIS RUTENDO MASHIRI

*School of Engineering, University of Tasmania
Private Bag 65, Hobart, TAS 7001, Australia
Fidelis.Mashiri@utas.edu.au*

XIAO-LING ZHAO

*Department of Civil Engineering, Monash University
Wellington Rd, Clayton, VIC. 3800, Australia*

MANFRED A. HIRT and ALAIN NUSSBAUMER

*Department of Civil Engineering
Ecole Polytechnique Federale de Lausanne
CH-1015, Lausanne, Switzerland*

Received 17 February 2006

Accepted 5 December 2006

This paper clarifies the terminologies used to describe the size effect on fatigue behavior of welded joints. It summarizes the existing research on size effect in the perspective of newly defined terminologies. It identifies knowledge gaps in designing tubular joints using the hot spot stress method, i.e. thin-walled tubular joints with wall thickness less than 4 mm and thick-walled tubular joints with wall thickness larger than 50 mm, or diameter to thickness ratio less than 24. It is the thin-walled tubular joints that are addressed in this paper. It is found that thin-walled tube-plate T-joints do not follow the conventional trend: the thinner the section is, the higher the fatigue life. It is also found that simple extrapolation of existing fatigue design curves may result in unsafe design of thin-walled tube-tube T-joints. The effect of chord stiffness on fatigue behavior of thin-walled tubular T-joints is also discussed.

Keywords: Size effect; thickness effect; welded joints; plate; tube; weld defects; fatigue.

1. Introduction

Fatigue life of welded joints depends on many parameters. Some of the parameters which influence fatigue life are among others, wall thickness of plates or tubes, weld shape and size, residual stress field and non-dimensional parameters of a connection. The wall thickness is sometimes regarded as the most important parameter when comparing the relative fatigue life of two welded joints, hence the term “thickness effect” is widely used in the literature^{1–5} and the term “thickness correction factor” is used in various standards.^{6–8} Other terms that are also found in the literature are “size effect”, “scaling effect” and “geometrical effect”.^{5,9,10} In addition to the aforementioned parameters, fatigue life of welded connections is also influenced by post weld treatment^{11,12} and the environment condition.^{13–15}

This paper attempts to clarify the terminologies. It briefly summarizes some of the previous research dealing with size effect. The newly defined terminologies are used to examine each research. The size effect in existing design recommendations for some tubular joints is summarized in the format of both classification method and hot spot stress method. The existing design recommendation based on hot spot stress method^{16,17} does not cover tubular joints with wall thickness less than 4 mm or larger than 50 mm or with 2γ value less than 24. The tubular joints with $t < 4$ mm is called thin-walled tubular joints while those with $t > 50$ mm or $2\gamma < 24$ are called thick-walled tubular joints in this paper. Reports on the thick-walled tubular joints can be found in Schumacher¹⁸ and Schumacher *et al.*⁹ Only the thin-walled tubular T-joints are addressed in this paper. The research in thin-walled tubular joints has been necessitated by the increased availability of thin cold-formed tubes made from high-strength steel. This has led to an increased use of welded thin-walled ($t < 4$ mm) tubes in the manufacture of structural systems subjected to cyclic loading such as agricultural and road transport industry equipment. The hollow sections are welded to form structural support systems in trucks, trailers, haymakers, swing-ploughs, linkage graders, traffic sign supports and lighting poles. These structural systems are subjected to cyclic loading in service. The conventional trend in fatigue S - N curve will be verified for such thin-walled tube-plate T-joints. The suitability of simply extrapolating existing fatigue design S - N curves for thin-walled tube-tube joints will be checked. Discussions are also made on the effect of chord stiffness on the fatigue behavior of thin-walled tubular T-joints.

2. Terminologies

Different terminologies were used in the literature when comparing the fatigue behavior of welded joints. This section aims to clarify the concept and define the new terminologies.

Fatigue life of welded joints may be affected by connection size and improvement technology. The fatigue life of welded connections can therefore be classified as influenced by two main components, i.e. size effect and improvement effect. The size effect includes statistical size effect, technological size effect and geometrical size effect. These three effects can be represented or studied quantitatively using a scaling effect when comparing the fatigue behavior of two welded joints. Details are explained below.

2.1. Size effect

2.1.1. Statistical size effect

Size effect in fatigue may be interpreted using the so-called statistical effect which stems from the fact that fatigue is a weakest link process, nucleating at the location where stresses, geometry, defects and material properties combine to form optimum conditions for fatigue crack initiation and growth. Increasing the size of a specimen will statistically produce locations that are more vulnerable to fatigue failures.¹⁹

Örjasaeter *et al.*²⁰ termed the statistical effect, the volume effect, and interpreted it as a correlation between the volume of highly stressed material and fatigue strength. A possibility to consider this effect is based on the weakest link theory proposed by Weibull²¹ and Savaidis *et al.*²² Fatigue tests of welded joints are influenced by the initiation and growth of small ellipsoidal cracks from the weld toe. The length of the weld toe from which the cracks initiate is therefore an influencing factor for fatigue strength since a larger length results in more likelihood of initiation and failure of the welded joint.²³

2.1.2. Technological size effect

Technological size effect results from differences in production parameters. For example, due to differences in rolling reduction ratios, the mechanical properties diminish with increasing plate thickness. This effect can be neglected if mechanical properties are essentially the same for different thicknesses. Technological size effect can be considered to occur as a result of varying residual stresses caused by welding in different plate thicknesses. Technological size effect can also be understood in terms of geometrical size effect at the mesoscale level, which originates from incomplete scaling. When all dimensions are scaled up or down equally, the material properties such as grain size, flaw dimensions and mechanical properties do not change.²³

2.1.3. Geometrical size effect (at the mesoscale level)

A model can be used for explaining the thickness effect in welded joints where fatigue cracks initiate from the weld toes.^{1,13} In this model the following assumptions are adopted: (i) welded joints of the same type in various plate thicknesses are geometrically similar. This is typical of load-carrying welded joints, and (ii) initial conditions of fatigue crack growth are independent of plate thickness. This means that the initial cracks in welds of different thicknesses are of the same magnitude. Therefore the stress distribution across the load-carrying plates in the crack growth plane are geometrically similar, leading to a steeper stress gradient in the thinner joint, according to assumption (i). Using assumption (ii), the initial crack in the thinner plate will experience a smaller stress than the initial crack of the same length in the thicker plate. This results in a smaller initial crack growth in the thinner joint.^{4,19}

2.2. Scaling effect

This paper introduces a new concept called “scaling effect”. The scaling effect includes complete proportional scaling, practical proportional scaling and non-proportional scaling. Complete proportional scaling is defined as the case where all factors affecting fatigue are scaled proportionally, whatever their origin (statistical, technological or geometrical). Practical proportional scaling is defined as the case where only important factors are scaled proportionally. Non-proportional scaling

is defined as the case where some important factors are not scaled proportionally. The more the parameters affecting the fatigue of a connection, the less chance to achieve a complete proportional scaling. In fact only very simple plated connection types (e.g. plate with transverse attachments) may achieve complete proportional scaling. For tubular joints, practical proportional scaling may be achieved if the important non-dimensional parameters ($\beta, \tau, 2\gamma$) are scaled proportionally. When thickness is the only parameter needed to describe the relative fatigue life of two joints, we call this case “complete” thickness effect. It only could happen under the condition of complete proportion of two joints. It is only possible for very simple welded joints such as transverse attachments. When thickness is one of the parameters needed to describe the relative fatigue life of two joints, we call the influence due to thickness “partial” thickness effect. When the influence of other parameters is insignificant, the “partial” thickness effect may be approximated as the “complete” thickness effect. In the expression describing the relative fatigue strength, there are two possible reference cases. When the reference thickness is the smaller one, it is called thickness correction factor, and when it is the larger one, it is called thinness correction factor.

The flowchart in Fig. 1 shows the two categories that can influence fatigue life. The flowchart shows in detail the different concepts that form part of the size and improvement effects.

2.3. Improvement effect

The improvement effect results from the enhancement in geometry and residual stress distribution within the welded connection due to post-weld treatments. The improvement of geometry in welded connections can result from processes such as weld toe grinding and TIG dressing. These processes cause a decrease in stress

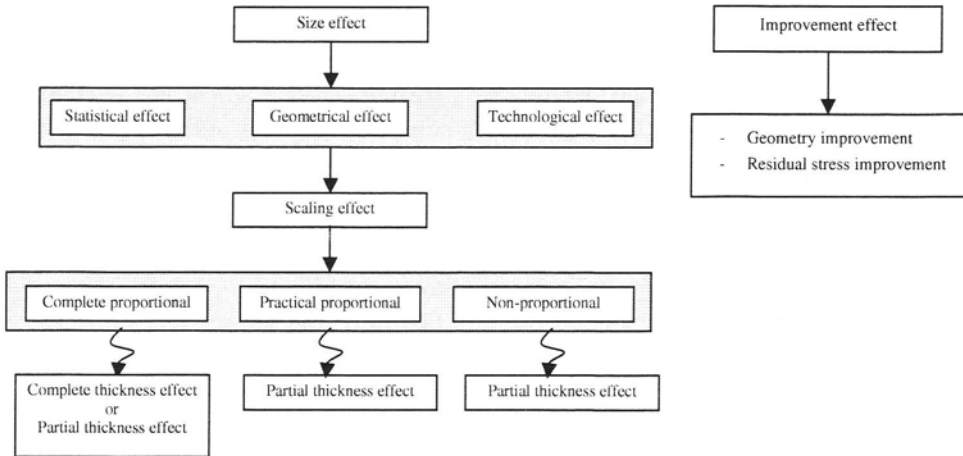

Fig. 1. Size and improvement effects and their corresponding concepts.

concentration due to the improved geometry at the toes of the weld, a result of a smoother and hence gradual transition between two welded plates or sections. The residual stress at weld toes can also be improved through processes such as hammer or shot peening which cause a reduction in tensile residual stresses or a change in residual stress at the locations of interest from tension to compression. More details can be found in Haagensen and Maddox¹² as well as Walbridge *et al.*²⁴ The improvement effect thus have different degrees of influences on all the size effects (statistical, technological and geometrical).

3. Existing Research on Size Effect

Apart from the researchers mentioned in the previous sections, numerous researchers have investigated the size effect phenomenon from as early as the 1950s to this day. This research has led to a better understanding of the influence of plate and/or tube-wall thickness on fatigue strength of welded connections. In his 1989 review, Gurney² pointed out that thickness effect could be demonstrated using both fracture mechanics theory and experimental work. This had led to the introduction of a thickness correction factor in the revised version of the UK Department of Energy Guidance Notes in 1984. Gurney² also noted that much earlier than the introduction of the thickness effect on fatigue of welded connections, Phillips and Heywood²⁵ had demonstrated the size dependence of fatigue strength of unwelded specimens. Gurney² also pointed out that it had long been known that plate thickness was likely to be a relevant variable for fatigue strength under bending stresses, because the stress gradient through the thinner specimen would be steeper and therefore less damaging than that in thicker specimens. Gurney²⁶ showed with the use of fracture mechanics theory, the fatigue strength of welded joints could be affected by plate thickness even when they were subjected to axial loading. Gurney²⁷ pointed out on the basis of fracture mechanics analysis and experimental evidence that the effect of plate thickness on fatigue strength could be significant.

Other researchers have also studied the behavior of welded plate, tubular and tube-plate joints with different wall thicknesses. This research has either strengthened the concept of thickness effect or culminated in the introduction of thickness correction factors in various standards around the world. In the majority of the research on plated specimens, the main plate and transverse plates are usually of equal thickness.

When thickness effect is studied using main plate and transverse plates of equal thickness, the category of scaling can be referred to as practical proportional scaling. This is because the most important parameter influencing thickness effect, is whether wall thickness of the plate is scaled proportionally. However, although the thickness is scaled proportionally in plated joints, other parameters such as weld size, though normally increasing with increasing thickness to cope with an increase in applied design load, may not be proportionally scaled, in particular in non-load carrying welded connections. Other parameters that also vary but not

Table 1. Summary of research on size effect.

| Reference | Type of Joint | Loading | Specimen Thickness (mm) | Test/Analysis Condition | Thickness Correction Factor Proposed | Category of Scaling | Complete or Partial Thickness Effect |
|--|----------------|---|-------------------------|---|--------------------------------------|--------------------------------|--------------------------------------|
| Mohaupt <i>et al.</i> ²⁸ ; Vosikovskiy <i>et al.</i> ³ | Plate T-joints | 3-point bending; Constant and variable amplitude in air | 16, 26, 52, 78, 103 | Joints tested in the as-welded condition. Stress ratio; $R = 0.05$; Joints with proportional and non-proportional scaling tested; Improved weld profile tested | — | Practical Proportional Scaling | Partial Thickness Effect |
| | | 3-point bending; Constant amplitude in seawater | 26, 78 | Joints tested in the as-welded condition in seawater were unprotected, optimum cathodically protected and overprotected | — | Practical Proportional Scaling | Partial Thickness Effect |
| Booth ²⁹ | Plate T-joints | 4-point bending; Constant amplitude in air | 25, 38, 50, 75, 100 | Joints tested in the as-welded condition, after PWHT and toe grinding; $R = 0$ | — | Practical Proportional Scaling | Partial Thickness Effect |
| Berge <i>et al.</i> ³⁰ | Plate T-joints | Cantilever loading system; Constant amplitude in air | 20, 100, 150 | Joints tested in as-welded condition | — | Practical Proportional Scaling | Partial Thickness Effect |

Table 1. (Continued)

| Reference | Type of Joint | Loading | Specimen Thickness (mm) | Test/Analysis Condition | Thickness Correction Factor Proposed | Category of Scaling | Complete or Partial Thickness Effect |
|---------------------------------------|-------------------------|---|-------------------------|--|--------------------------------------|--------------------------------|--------------------------------------|
| Overbeeke and Wildschut ²³ | Plate T-joints | Pure bending; Constant amplitude in air | 16, 25, 40, 70 | Joints tested after PWHT | See Note 1 | Practical Proportional Scaling | Partial Thickness Effect |
| | | Pure bending; Constant amplitude in seawater | 16, 40 | Joints tested in the as-welded condition, after toe grinding; Seawater temperature showed no influence | — | Practical Proportional Scaling | Partial Thickness Effect |
| Xue <i>et al.</i> ¹⁴ | Cruciform welded joints | 4-point bending, cantilever bending; Constant amplitude in air, seawater with and without cathodic protection | 16, 32, 40 | Joints tested in the as-welded condition at a stress ratio, R of -1 | See Note 2 | Practical Proportional Scaling | Partial Thickness Effect |

Note 1: The thickness effect for connections in the stress relieved condition is $S = S_B(t_B/t)^{0.15}$.

Note 2: The thickness correction factors proposed are as follows: In air, $S = S_B(t_B/t)^{1/3}$; Freely corroding in sea-water, $S = S_B(t_B/t)^{1/4}$; In sea-water with cathodic protection (-850 mV. SCE), $S = S_B(t_B/t)^{1/2}$.

Table 1. (Continued)

| Reference | Type of Joint | Loading | Specimen Thickness (mm) | Test/Analysis Condition | Thickness Correction Factor Proposed | Category of Scaling | Complete or Partial Thickness Effect |
|--|---|--|--|--|--------------------------------------|--------------------------------|--------------------------------------|
| Orjasaeter <i>et al.</i> ²⁰ | Plate T-joints | Cantilever bending; 3-point bending; Constant amplitude in air | 30, 70, 100, 130, 160 | Joints tested in as-welded condition and after PWHT; R = 0.1 | — | Practical Proportional Scaling | Partial Thickness Effect |
| Noordhoek <i>et al.</i> ³¹ | Plate T-joints | 4-point bending; Constant amplitude in air | Main plate $t = 70$ and 160 mm with transverse/longitudinal plates of $t = 20$ and 45 mm | Joints tested in the as-welded condition; Thickness effect due to non-proportional scaling of main and attachment plate thickness; R = 0 | — | Non-Proportional Scaling | Partial Thickness Effect |
| Gurney ² | Plates with longitudinal edge attachments | Tensile cyclic loading | Width between longitudinal attachments, $W = 40, 80, 125, 200$ | Joints tested in a stress relieved condition, R = 0 | See Note 3 | Non-Proportional Scaling | Partial Thickness Effect |
| Eide and Berge ³² | Plate Girders | 4-point bending | 20, 40, 60 | Joints tested in the as-welded condition | — | Non-Proportional Scaling | Partial Thickness Effect |
| Van Delft <i>et al.</i> ³³ | Tubular T-, Y-, X-, K- & KT-joints | Axial, in-plane bending and out-of-plane bending | 10, 20, 40, 80, 160 | Joints tested in the as-welded and stress relieved conditions; Data from 200 specimens analyzed | See Note 4 | Non-Proportional Scaling | Partial Thickness Effect |

Table 1. (Continued)

| Reference | Type of Joint | Loading | Specimen Thickness (mm) | Test/Analysis Condition | Thickness Correction Factor Proposed | Category of Scaling | Complete or Partial Thickness Effect |
|---|--------------------------------|---|---|--|--------------------------------------|--------------------------|--------------------------------------|
| Van Wingerde <i>et al.</i> ⁵ | Tubular T-, Y-, X-, & K-joints | Axial, in-plane bending and out-of-plane bending; Tested in air | 4, 5, 8, 10, 12, 16, 25, 32, 50 | Data from 238 specimens analyzed | See Note 5 | Non-Proportional Scaling | Partial Thickness Effect |
| IIW ³⁴ | Cruciform joints | Axial | Thickness greater than or equal to 25mm | Joints tested in the as-welded, toe ground | See Note 6 | Non-Proportional Scaling | Partial Thickness Effect |

Note 3: Gurney² suggested from the limited test data that joints with an attachment on or adjacent to the edge of the plate under a stress range could be corrected by $S = S_B(W_B/W')^{1/4}$ where W_B is the basic width corresponding to the basic design S - N curve ($W_B = 100$ mm), W' is the apparent width of the plate under consideration. Gurney² also suggested that $W' = W$, if $L > W$ or $W' = L$ if $L < W$, where W is the actual plate width and L is the attachment length in the direction of stress.

Note 4: The relation between the hot spot strain range (HSSNR), number of cycles to crack through (N_c) and the wall thickness of the cracked member (T_{cr}) from the regression analysis was found to be, $\log \text{HSSNR} = 4.53 - 0.175 \cdot \log N_c + 0.075 \cdot \log N_c \cdot \log T_{cr}$.

Note 5: Thickness correction is based on statistical analysis of the database and is of the form: $S_{\text{rhs},t} = S_{\text{rhs},16} \cdot (16/t)^{-0.06 \cdot \log N}$.

Note 6: Thickness correction is of the form, $S = S_B \cdot (25/t_{\text{eff}})^n$, see Sec. 3.5.2.2 of IIW³⁴ for further details.

proportionally are the weld toe conditions such as weld toe radius and the residual stress magnitude due to welding. If the plate thickness, weld size, weld toe radius and residual stresses are increased proportionally from specimen to specimen, then complete proportional scaling is deemed to have occurred. This condition is difficult to achieve in real structures. When the main plate, transverse or longitudinal plate thickness, or dimensions are not directly linked to the applied design load, then we have a case of practical or non-proportional scaling.

Some of the existing research is summarized in Table 1. The summary shows the type of joints tested, the load type applied and the thicknesses of the plates and tubes tested. The different loads applied confirm the fact that thickness effect is observed in joints regardless of the type of load to which the connection is subjected to. The category of scaling used in the studies is shown in Table 1 and the thickness correction factors suggested by some of the researchers are given as footnotes in Table 1.

Table 1 shows that most of the fatigue data that is used in deriving the thickness correction factors for welded plate joints comes from specimens with practical proportional scaling. For welded tubular nodal joints, non-proportional scaling mainly occurs. Practical proportional scaling and non-proportional scaling results in what is termed partial thickness effect as shown in Fig. 1. It can be seen that there are no studies on thin-walled tubular joints ($t < 4$ mm) reported in Table 1, i.e. on what is called the thinness effect. This will be the subject of Secs. 5–7 of this paper.

The size effect in welded joints is of the form $S = S_B(t_B/t)^n$, where S_B is the fatigue strength for a reference plate thickness, t_B and S is the fatigue strength for a plate thickness, t under consideration and n is less than 1.0. More details are given in Notes 1–6 of Table 1.

4. Size Effect in Existing Design Recommendations for Tubular Joints

4.1. Classification method

Various standards around the world have adopted thickness correction factors or design $S-N$ curves that depict thickness effect. Thickness correction factors are obtained by plotting the relative fatigue strength versus the thickness of the failing member. Gurney² obtained the relationship between fatigue strength and thickness of a member under failure by plotting the relative fatigue strength normalized to a reference thickness of 32 mm versus the thickness of different plate and tubular joints. Thickness correction factors have been adopted in standards such as those from the International Institute of Welding,^{8,16} the British Standards,^{7,35} the European Standard,³⁶ CIDECT Design Guide No. 8¹⁷ and Australian Standard,⁶ with however different values for the reference thickness. The thickness correction factors can be used to predict the fatigue strength of wall thicknesses other than the reference thickness.

Table 2. Size effect in existing standards using classification method (some examples).

| Detail Category | Constructional Details | Description | Reference | Remarks |
|---|---|--|-----------------------------------|--|
| 45 ($t \geq 8 \text{ mm}$) 40 ($t < 8 \text{ mm}$) |  | Fillet welds to intermediate plate: Circular hollow sections, end-to-end fillet welded with an intermediate plate | AS4100 ⁶ | May be approximated as complete thickness effect |
| E (80) |  | Butt welded circular hollow sections: Weld made from both sides | BSI 7608 ³⁵ | May be considered as partial thickness effect because the manufacturing method (technological size effect) is also an influencing factor |
| F (68) | | Butt welded circular hollow sections: Weld made from one side on permanent backing strip | | |
| F2 (60) | | Butt welded circular hollow sections: Weld made from one side with no backing strip | | |
| 90 ($\frac{t_0}{t_t} \geq 2.0$) |  | CHS gap K and N joints | Eurocode 3 Part 1.9 ³⁶ | May be considered as partial thickness effect because the thickness ratio is also an influencing factor |
| 45 ($\frac{t_0}{t_t} = 1.0$) | | | | |

Table 3 shows the size effect in tubular connections in some existing standards in the format of classification method. In the classification method, the fatigue strength of a constructional detail relates the nominal stress range, due to the applied member loads, to the number of cycles to failure. The first example in Table 2 (fillet welded circular hollow sections) may be approximated as the case of complete thickness effect. The other two examples in Table 2 may be considered as “partial thickness effect” because the fatigue life is also influenced by manufacturing method for the second example or other non-dimensional parameters for the third example.

4.2. Hot spot stress method

The hot spot stress method relates to the hot spot stress range to the number of cycles to failure. The fatigue design curves from CIDECT Design Guide No. 8¹⁷ and IIW¹⁶ are shown in Fig. 2 with some explanation given in Table 3. It can be seen from Table 3 that the size effect may be considered “partial thickness effect” because other parameters also influence the fatigue life. It is also interesting to note that the thickness correction factor in Table 3 also depends on the number of cycles to failure (N). This stems from the fact that in the low cycle fatigue range, thickness effect is less pronounced.³⁷ Thickness effect therefore tends to be pronounced as the number of cycles to failure increases.

Figure 2 shows the current limitations of the fatigue design curves in IIW¹⁶ and CIDECT Design Guide No. 8.¹⁷ The limitations in these standards, as shown in Fig. 2, are such that there are no fatigue design curves for thin-walled tubular joints ($t < 4$ mm) and for thick-walled joints ($t > 50$ mm or $2\gamma < 24$). This paper addresses the size effect of thin-walled tubular joints in the next sections (Secs. 5–7). The size

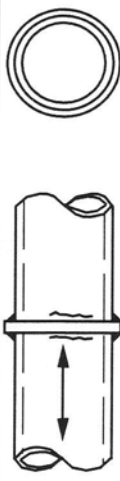
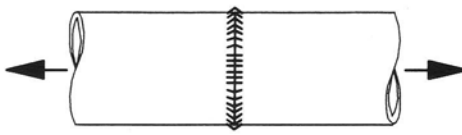
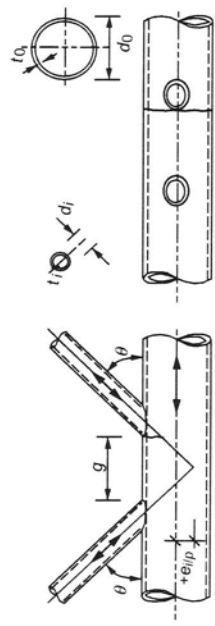
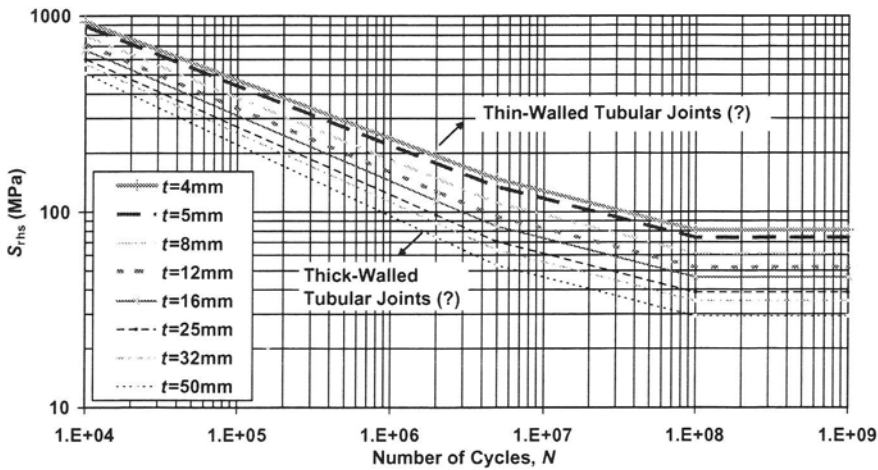

Fig. 2. Fatigue design curves for tubular nodal joints in standards^{16,17} and knowledge gaps identified.

Table 3. Size effect in existing standards using hot spot stress method.

| Type of Joints | Thickness Correction Factor | Description | SCFs | References | Remarks |
|---|---|---|--|--|--|
| Uniplanar T, X, Y, K tubular joints and multiplanar XX, KK tubular joints | $S = S_B \cdot (16/t)^{-0.06 \cdot \log N}$ | Design $S-N$ curves in the hot spot stress method are defined by the following equations for different tube wall thicknesses: $\log(N) = \frac{12.476 - 3 \cdot \log(S_{rhs})}{1 - 0.18 \cdot \log(16/t)}$ for $10^3 < N < 5 \cdot 10^6$ and $\log(N) = 16.327 - 5 \cdot \log(S_{rhs}) + 2.01 \cdot \log(16/t)$ for $5 \cdot 10^6 < N < 10^8$ (for variable amplitude only). Equations for hot spot $S-N$ curves for CHS joints ($4 \text{ mm} \leq t \leq 50 \text{ mm}$) and RHS joints ($4 \text{ mm} \leq t \leq 16 \text{ mm}$) | A function of β , 2γ and τ | IIW ¹⁶ and Zhao <i>et al.</i> ¹⁷ | May be considered as partial thickness effect because other parameters (β , 2γ and τ) are also influencing factors |

effect in nodal joints made up of relatively thick-walled tubular connections was reported by Schumacher.¹⁸ A more comprehensive study on size effect in welded thick-walled joints was compiled and reported by Schumacher *et al.*⁹

5. Size Effect of Welded Thin Tube-Plate T-Joints

There has been an increased availability in high strength cold-formed steel tubes in different steel markets around the world.^{38–42} This has led to the use of these tubes, which are mainly thin-walled, in the manufacture of equipment and construction of structural systems some of which are subjected to cyclic loading.^{43–45} The lack of fatigue design rules for welded tubes of wall thicknesses less than 4 mm has prompted interest among researchers to investigate their fatigue strength.

An investigation into the fatigue strength of welded thin-walled circular hollow section to plate (CHS-Plate) and square hollow section to plate (SHS-Plate) T-joints was carried out at Monash University and reported by Mashiri *et al.*^{43,44} and Mashiri and Zhao.⁴⁶ Thin-walled circular hollow section (CHS) and square hollow section (SHS) tubes were welded onto 10 mm thick plates and the resulting CHS-Plate and SHS-Plate T-joints subjected to cyclic in-plane bending moment through the CHS or SHS brace as shown in Fig. 3. Specimens were tested at a stress ratio of 0.1. 17 welded thin-walled ($t < 4$ mm) CHS-Plate and 35 welded thin-walled ($t < 4$ mm) SHS-Plate T-joints were tested.

The parameters in tube-plate T-joints that are likely to contribute to the fatigue strength are the thickness of the plate T , the thickness of the tube, t_1 , and the weld size and weld toe conditions. Compared to the tube wall thicknesses which ranged between 1.6 mm and 3.0 mm, the plate thickness of 10 mm is significantly large. Since no cracks occurred in the plate, the plate thickness can be considered to have negligible influence on the fatigue strength of the tube-plate T-joints except to provide a rigid base upon which the tube could bend. Research has shown that in welded thin-walled ($t < 4$ mm) joints, the welds are oversized.⁴⁷ The measured

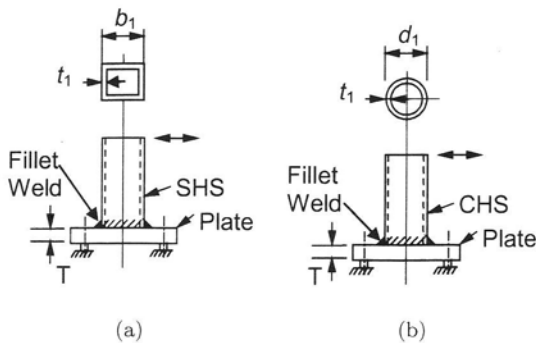

Fig. 3. (a) SHS-Plate and (b) CHS-Plate T-joints under cyclic in-plane bending (bolted to rigid plates).

average leg length for the thin-walled connections was about 6 mm as reported in Mashiri *et al.*⁴⁵ For tube wall thicknesses less than 4 mm, the weld size is oversized since only a minimum size of weld can be deposited during welding. Since the plate and weld sizes are constant in this investigation, the main parameter influencing fatigue life is the tube wall thickness, t_1 . In this study, the changing of the tube wall thickness (t_1) can be considered as practical proportional scaling. The comparison of the fatigue strength at different tube wall thickness, in this investigation, therefore represents a partial thickness effect as shown in Fig. 1.

Tubes of different wall thicknesses were used in making the tube-plate T-joint specimens. For the thin CHS-Plate T-joints, circular hollow sections of thicknesses equal to 2.0, 2.6 and 3.2 mm were used. For the thin SHS-Plate T-joints, square hollow sections of thicknesses equal to 1.6, 2.0, and 3.0 mm were used. Since failure of the tube-plate T-joints occurred in the tubular brace members, the relative fatigue strength of the welded tubes with different wall thicknesses can be assessed. The fatigue strength of the welded thin-walled tubes with different wall thicknesses can be used to verify the thickness effect in welded thin-walled joints and compare it with existing trends in thickness effect for relatively thicker joints with wall thicknesses typically greater than 25 mm for plated joints and greater than 4 mm for tubular joints.

Figures 4 and 5 show the mean $S-N$ curves for welded thin-walled tube-plate T-joints made up of different tube wall thicknesses for the SHS-Plate and CHS-Plate T-joints respectively. In the regression analyses, a slope coefficient of 3 has been imposed. Figures 4 and 5 show that for welded thin-walled ($t < 4$ mm) tubes the fatigue strength decreases as the welded tube failing due to fatigue loading becomes thinner. This is not considered in design codes such as AS4100-1998,⁶ EC3,³⁶

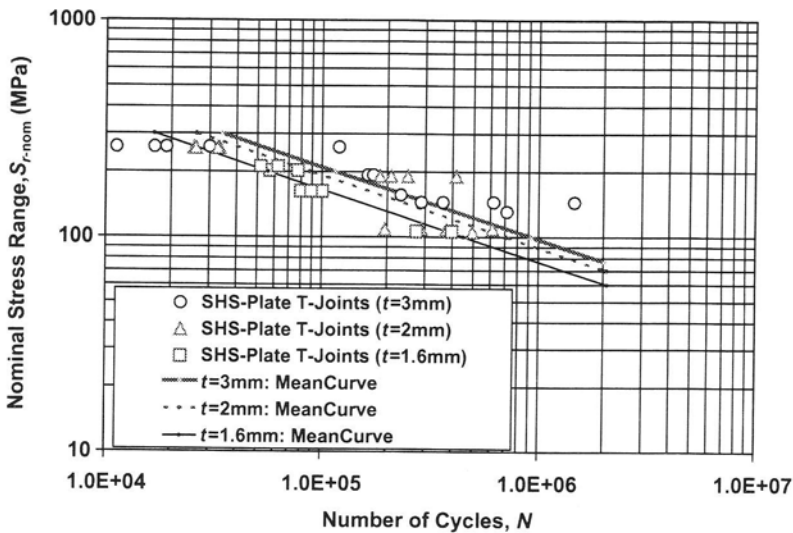

Fig. 4. Effect of tube wall thickness on fatigue life in thin SHS-Plate T-joints.

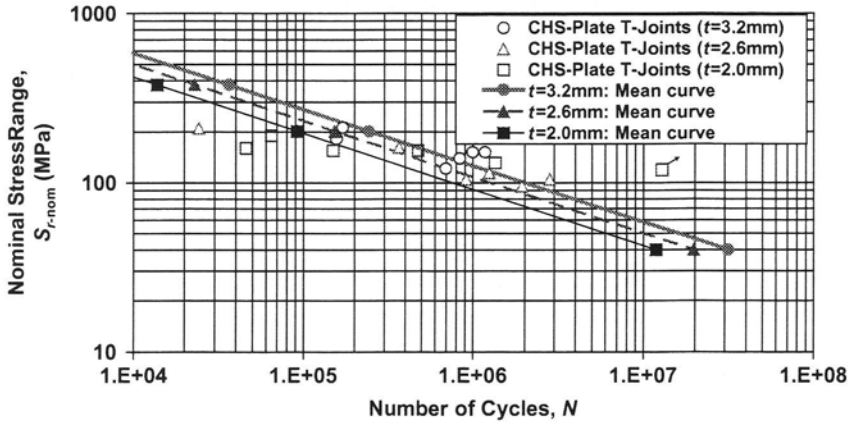

Fig. 5. Effect of tube wall thickness on fatigue life in thin CHS-Plate T-joints.

Department of Energy⁷ and Hobbacher⁸ and the new fatigue design guidelines on nodal tubular joints using the hot spot stress method IIW¹⁶ and Zhao *et al.*¹⁷ It should also be noted that the thicknesses of tubes used in the manufacture of the thin-walled CHS-Plate and SHS-Plate T-joints are outside the range of application of the thickness correction factors given in existing codes. The decrease in fatigue strength, shown in Figs. 4 and 5, as the tube wall thickness becomes smaller, for tube wall thicknesses below 4 mm, can be attributed to the greater negative impact of weld toe defects such as undercut on fatigue crack propagation life of thin-walled ($t < 4$ mm) joints as reported by Mashiri *et al.*^{43,48} Previous research by Noordhoek *et al.*⁴⁹ reported on a similar phenomenon and attributed it to the difficulty associated with the welding of smaller wall thickness sections.

A summary of the recommended fatigue design S - N curves for welded thin-walled tube-plate T-joints in the classification method is given in Mashiri and Zhao.⁴⁶

6. Size Effect of Welded Thin Tube–Tube T-Joints

A study into the fatigue strength of welded thin-walled SHS-SHS, CHS-SHS and CHS-CHS T-joints under cyclic in-plane bending as shown in Fig. 6, was recently carried out at Monash University and reported by Mashiri *et al.*^{45,48} The SHS-SHS T-joints were made up of square hollow section (SHS) chords of 3 mm thicknesses as well as SHS braces of thicknesses 3 mm, 2 mm and 1.6 mm. The CHS-SHS T-joints were made up of 3 mm thick square hollow section chords and circular hollow section braces of thicknesses 2 mm, 2.3 mm, 2.6 mm and 2.9 mm. For the CHS-CHS T-joints, the chord members were 3.2 mm thick circular hollow sections whereas the brace members were of thicknesses 2.0 mm, 2.3 mm, 2.6 mm and 3.2 mm.

The range of parameters for the tube–tube T-joints tested are shown in Fig. 6. The parameters given in Fig. 6 include the thickness and the non-dimensional parameters. The non-dimensional parameters are, the brace to chord

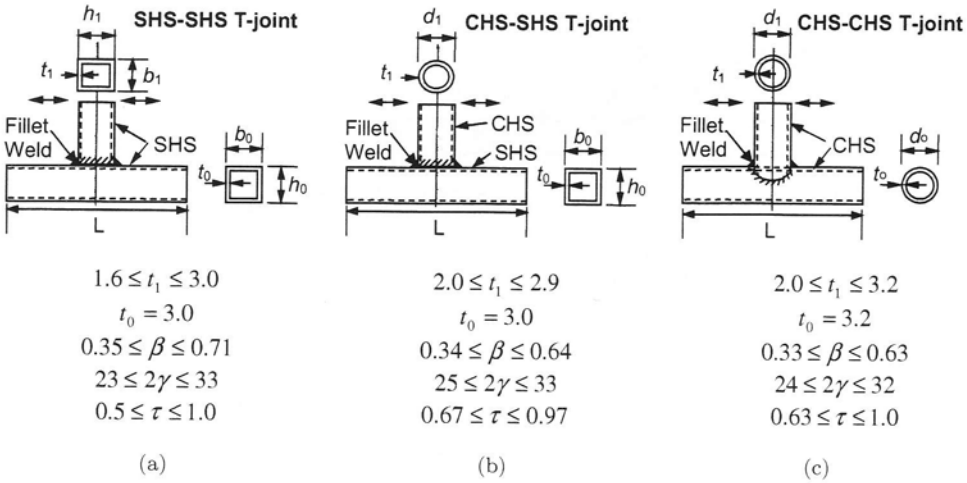

Fig. 6. (a) SHS-SHS, (b) CHS-SHS and (c) CHS-CHS T-joints under in-plane bending (simply supported at both ends).

width/diameter ratio, β , the chord width/diameter to chord wall thickness ratio, 2γ ; and the brace to chord wall thickness ratio, τ . These parameters are not proportionally scaled. According to Fig. 1, this investigation can be referred to as involving non-proportional scaling. The study in tubular nodal joints therefore deals with partial thickness correction. 58 welded thin-walled ($t < 4$ mm) SHS-SHS, 23 welded thin-walled ($t < 4$ mm) CHS-CHS and 18 welded thin-walled CHS-SHS T-joints were tested. Photographs of failures in thin tube-tube as well as thin tube-plate T-joints under cyclic in-plane bending are shown in Mashiri *et al.*^{45,48} and Mashiri and Zhao⁴⁶ respectively.

Fatigue failure occurred in the 3 mm SHS chords for SHS-SHS and CHS-SHS T-joints and hence the critical thickness for the S - N data obtained was 3 mm. The critical tube wall thickness in the CHS-CHS T-joints is 3.2 mm since failure only occurred in the 3.2 mm thick chords. The resulting S - N data from this investigation was analyzed using the hot stress method and compared to existing fatigue design guidelines for tubular nodal joints.

Figure 7 presents the existing $S_{\text{rhs}}-N$ design curves for tubular nodal joints from the CIDECT Design Guide No. 8¹⁷ and IIW.¹⁶ The existing $S_{\text{rhs}}-N$ curves show that for a given hot spot stress range, fatigue life increases as the thickness of the member failing under fatigue loading becomes smaller. This trend is in agreement with the conventional concept of thickness effect. The equations that can be used to determine the design $S_{\text{rhs}}-N$ curves for the different tube wall thicknesses in tubular nodal joints are those derived by van Wingerde *et al.*⁵ and shown in Table 3, which are however limited to tubes with $t \geq 4$ mm.

Using the current trend in CIDECT Design Guide No. 8¹⁷ and IIW,¹⁶ the extrapolated design $S_{\text{rhs}}-N$ curve for a critical thickness of 3 mm is shown in Fig. 7. It can be seen that the fatigue test data for the CHS-CHS, CHS-SHS and SHS-SHS T-joints are much lower than the extrapolated IIW curve with t of 3 mm. It

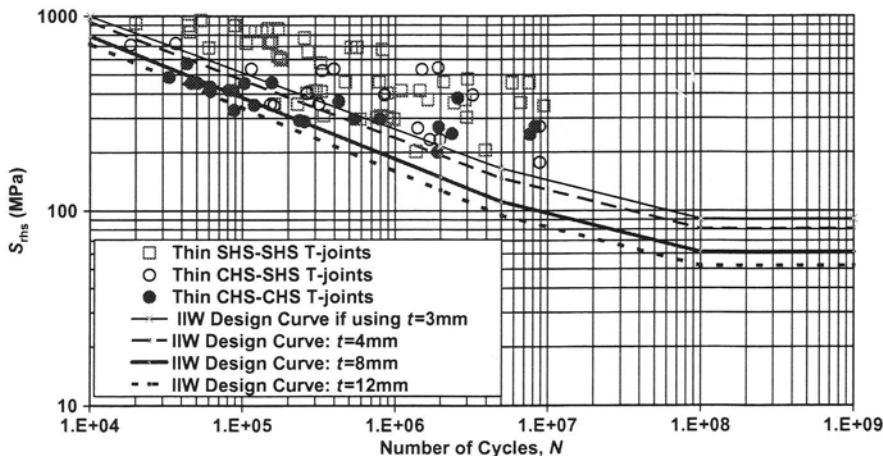

Fig. 7. Existing design S_{rms} - N curves from IIW¹⁶ and fatigue test data for welded thin-walled ($t < 4$ mm) CHS-CHS, CHS-SHS and SHS-SHS T-joints.

seems that simply extrapolating the existing S - N curve results in unsafe design of thin-walled tubular joints. The reduced fatigue life of welded thin-walled specimens can be attributed to the greater negative impact of weld toe undercut on fatigue crack propagation life as reported in Mashiri *et al.*^{50,51} Note that the tube wall thicknesses in the tested thin CHS-CHS, CHS-SHS and SHS-SHS T-joints all lie outside the validity range of the thicknesses currently covered by CIDECT Design Guide No. 8¹⁷ and IIW.¹⁶

Weld defects are an inherent product of welding. During the welding process, there will always be a minimum size of welding defects such as undercut. Since crack propagation occurs at the weld toes, the surface defects such as undercut are an important factor in the fatigue crack propagation life of welded joints. The size of the minimum undercut dimensions remains constant regardless of the tube wall thickness. The depth of undercut, for example, becomes a significant proportion of the thickness of the tube or plate as the tube/plate thickness decreases as is the case for thin-walled joints. This means that the detrimental effect of weld toe undercut, on fatigue crack propagation becomes significant.

A summary of the recommended fatigue design S - N curves for welded thin-walled tube-tube T-joints in the hot spot stress method is given in Mashiri and Zhao.⁵³

7. Effect of Chord Stiffness in T-Joints

7.1. General

T-joints of different stiffness have been tested during the investigations on fatigue of thin-walled joints. They are tube-plate, tube-tube and concrete-filled chord T-joints as shown in Fig. 8 with their corresponding range of parameters.

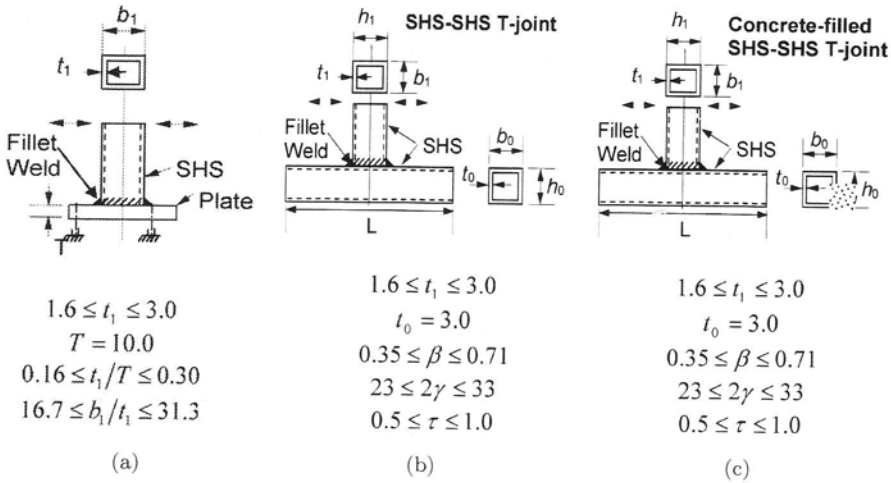

Fig. 8. (a) SHS-Plate (bolted to rigid plate), (b) empty SHS-SHS (simply supported at both ends) and (c) concrete-filled chord SHS-SHS T-joints under in-plane bending (simply supported at both ends).

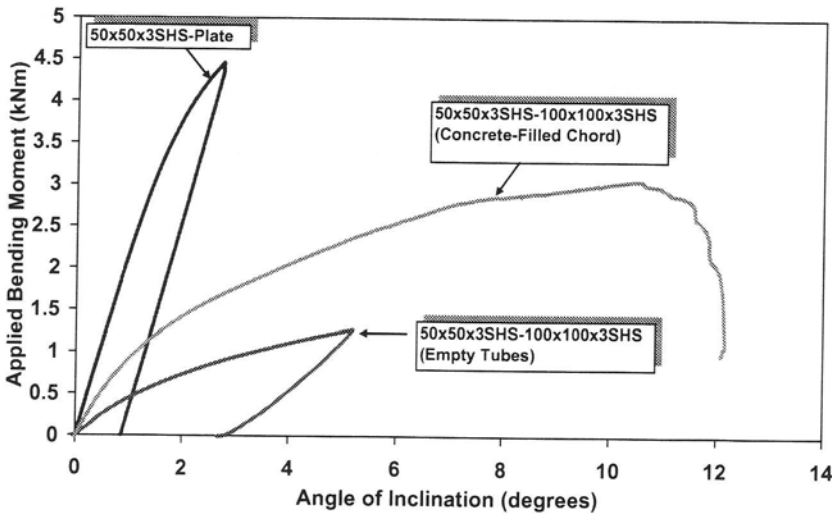

Fig. 9. Applied bending moment versus angle of inclination in joints of different stiffness.

Figure 9 shows the moment-angle of inclination graphs of SHS-SHS, SHS-Plate and SHS-SHS concrete-filled chord T-joints. The SHS-Plate T-joints have the highest stiffness of the three joints followed by the SHS-SHS concrete-filled chord T-joints. The SHS-SHS T-joints are the least stiff of the three joint types. The stiffest joint has the highest moment-angle of inclination ratio in the linear elastic part of the curve. The stiffest joint also has the largest static strength. The service loads that a connection can carry are dependent on the static strength of the

connection. Since the service loads applied to a structure determines the service life of a connection under cyclic loading, the stiffness of a connection is therefore likely to be a factor that influences the fatigue strength of a joint.

7.2. Stress concentration factors in joints of different stiffness

The maximum experimental stress concentration factors (SCFs) for the concrete-filled chord and the empty SHS-SHS T-joints under in-plane bending in the brace are shown in Table 4. The maximum SCFs in the tubular nodal T-joints occur at weld toes in the chord.⁵² Table 4 shows that for joints with the same non-dimensional parameters the concrete-filled chord T-joints have a smaller stress concentration factor compared to the SHS-SHS T-joints. The lower SCFs in the concrete-filled chord T-joints can be attributed to the increased rigidity and reduced chord face flexibility caused by the concrete in-fill in the chord member.⁵² Table 4 also shows that the ratio of the maximum SCF in a welded composite tubular T-joint to the maximum SCF in an empty joint is less than 1, with values as low as 0.3. However, an anomaly occurred in test series S6S1, where the maximum SCF in the welded composite tubular T-joint was larger than the maximum SCF in the corresponding empty joint. This may be attributed to errors in strain gauge placement and the sensitivity of the quadratic extrapolation method to smaller distances of extrapolation characteristic in thin-walled ($t < 4$ mm) joints. Poor concrete filling in the vicinity of the strain gauge location may also result in this type of error.

For thin SHS-Plate T-joints, the maximum stress concentration factors at the brace-plate interface were found to occur at weld toes in the square hollow section brace.⁴³ The stress concentration factors are summarized in Table 5. Table 5 shows that the maximum SCFs obtained in thin SHS-Plate T-joints were less than 2. This observation points to the fact that joints which are stiffer have smaller SCFs. The smaller magnitude of the SCFs in stiffer joints means that they will inherently have a better fatigue life.

7.3. Fatigue life of joints with different stiffness

The fatigue $S-N$ data for the welded composite tubular T-joints is plotted in Fig. 10 together with the $S-N$ data from empty hollow section SHS-SHS T-joints and that of thin SHS-Plate T-joints in the format of classification method. The first observation is that the concrete filled SHS-SHS T-joints data do not follow well the $S-N$ curve slope, imposed as 3 in the regression. Figure 10 shows that on average the welded composite tubular T-joints have a better fatigue life compared to the empty SHS-SHS T-joints. The $S-N$ data for the welded composite tubular T-joints lie either above the $S-N$ data plots for the empty SHS-SHS T-joints or on the upper bound of the scatter for the empty SHS-SHS T-joints. Figure 10 shows that the lower bound curve for concrete-filled chord T-joints under bending has a class (stress range at 2 million cycles) that is about 1.25 that of empty SHS-SHS T-joints.

Table 4. Experimental stress concentration factors in thin SHS-SHS T-joints and concrete-filled chord SHS T-joints under in-plane bending.

| Series Name | Chord Member $b_0 \times h_0 \times t_0$ | Brace Member $b_1 \times h_1 \times t_1$ | Non-Dimensional Parameters | | Maximum Measured SCFs | | Ratio of Max. SCFs $\frac{SCF_{Composite}}{SCF_{Empty}}$ | |
|-------------|---|---|--|---|--|------------------------------------|---|--------------------|
| | | | $\beta \left(= \frac{b_1}{b_0} \right)$ | $\tau \left(= \frac{t_1}{t_0} \right)$ | $2\gamma \left(= \frac{b_0}{t_0} \right)$ | Concrete-Filled Chord SHS T-Joints | | Empty SHS T-Joints |
| S3S1 | 100 × 100 × 3SHS | 50 × 50 × 3SHS | 0.50 | 1.00 | 33.3 | 8.0 | 12.0 | 0.67 |
| S3S2 | 100 × 100 × 3SHS | 50 × 50 × 1.6SHS | 0.50 | 0.53 | 33.3 | 6.4 | 7.1 | 0.90 |
| S3S4 | 100 × 100 × 3SHS | 35 × 35 × 3SHS | 0.35 | 1.00 | 33.3 | 6.3 | 12.7 | 0.50 |
| S3S5 | 100 × 100 × 3SHS | 35 × 35 × 1.6SHS | 0.35 | 0.53 | 33.3 | 4.8 | 5.9 | 0.81 |
| S6S1 | 75 × 75 × 3SHS | 50 × 50 × 3SHS | 0.67 | 1.00 | 25.0 | 10.8 | 8.4 | 1.29 |
| S6S2 | 75 × 375 × 3SHS | 50 × 50 × 1.6SHS | 0.67 | 0.53 | 25.0 | 2.5 | 8.3 | 0.30 |

Table 5. Experimental stress concentration factors for thin SHS-Plate T-joints.

| Series Name | Brace Member | Plate Size | $\left(= \frac{t_1}{t_P} \right)$ | $\left(= \frac{b_1}{t_1} \right)$ | Maximum Measured SCFs |
|-------------|------------------|------------------|------------------------------------|------------------------------------|-----------------------|
| S1P | 50 × 50 × 3SHS | 190 × 190 × 10PL | 0.30 | 16.7 | 1.8 |
| S2P | 50 × 50 × 1.6SHS | 190 × 190 × 10PL | 0.16 | 33.3 | 1.6 |
| D7P | 40 × 40 × 2SHS | 190 × 190 × 10PL | 0.20 | 20 | 1.6 |

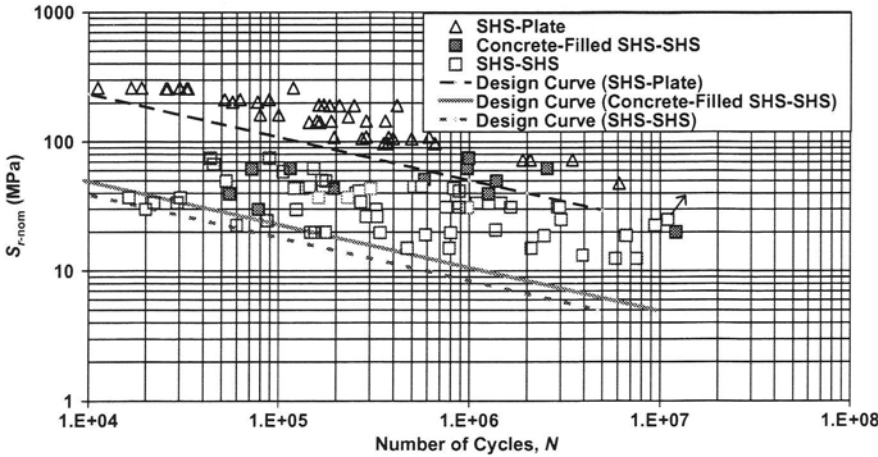

Fig. 10. *S-N* data and lower bound curves for thin SHS-Plate, SHS-SHS and concrete-filled SHS-SHS T-joints.

In terms of fatigue life, the welded composite tubular T-joints have about 2 times the fatigue life of empty SHS-SHS T-joints under a given nominal stress range.

When compared to concrete-filled chord SHS T-joints, the lower bound curve for thin SHS-Plate T-joints has a class that is about 4.8 times that of concrete-filled chord SHS T-joints. In terms of fatigue life, the thin SHS-Plate T-joints have a service life that is about 100 times that of the composite SHS T-joints for a given nominal stress range.

8. Conclusions

The following observation and conclusions are made:

- (a) A definition was given for scaling effect which includes complete proportional, practical proportional and non-proportional scaling. Complete thickness effect only occurs under the condition of complete proportional scaling.
- (b) The study of size effect in welded plate joints generally occurs under practical proportional scaling thereby resulting in a partial thickness effect being obtained. However in circumstances where the weld and weld toes conditions

- are almost proportionally scaled, the category of scaling can be approximated to complete proportional scaling resulting in complete thickness effect.
- (c) The study of size effect in welded tubular nodal joints occurs under non-proportional scaling resulting in a partial thickness being derived.
 - (d) More research needs to be undertaken to understand the trend of thickness effect in thicker walled joints, with tube wall thicknesses or 2γ beyond the current validity range in fatigue design guidelines for welded tubular joints.
 - (e) The conventionally accepted phenomenon of size effect shows that fatigue strength increases as the thickness of the member failing under fatigue decreases. Recent research on welded thin-walled ($t < 4$ mm) tube-plate and tube-tube T-joints has however shown that below a thickness of 4 mm, fatigue strength actually decreases as the member failing under fatigue becomes thinner. This observation in thin-walled joints can be attributed to the greater negative impact that weld toe defects such as undercuts have on fatigue crack propagation life.
 - (f) It has been demonstrated that boundary conditions have an effect on the relative fatigue strength of welded joints. Joints with a higher stiffness have a better fatigue life compared to joints of lower stiffness when subjected to the same nominal stress range.

Acknowledgments

The authors would like to thank Dr. Ann Schumacher at Swiss Federal Laboratories for Materials Testing and Research (EMPA) for her discussion on the terminologies described in this paper. The second author is grateful to ICOM, EPFL Lausanne for providing support during his sabbatical leave when part of this paper was prepared.

Appendix — Notation

$2\gamma = (b_0/t_0)$ or (d_0/t_0) , chord width or chord diameter
to chord wall thickness ratio

t = tube wall thickness

$\tau = (t_1/t_0)$, brace wall to chord wall thickness ratio

$\beta = (b_1/b_0), (d_1/d_0)$, brace width to chord width ratio
or brace diameter to chord diameter ratio

N = number of cycles to failure

t_0 = chord wall thickness

t_1 = brace wall thickness

SHS = square hollow section

CHS = circular hollow section

S = stress range

S_{rhs} = hot spot stress range

SCF = stress concentration factor

- b_1 = brace width
 b_0 = chord width
 d_1 = brace diameter
 d_0 = chord diameter
 $S_{r\text{-nom}}$ = nominal spot stress range
 T = plate wall thickness
 PWHT = post weld heat treatment
 S_B = stress range of reference plate thickness t_B
 t_B = reference plate thickness
 W_B = basic width corresponding to the basic design S - N curve.
 W' = apparent width of the plate under consideration
 HSSNR = hot spot strain range
 N_c = number of cycles to through thickness crack
 T_{cr} = wall thickness of cracked member
 $S_{r\text{rhs},t}$ = hot spot stress range for tube wall thickness, t .
 $S_{r\text{rhs},16}$ = hot spot stress range for reference tube wall thickness,
 $t = 16$ mm
 t_{eff} = effective thickness of main plate in cruciform type joints
 $SCF_{\text{composite}}$ = stress concentration factor for SHS-SHS T-joint
 with concrete filled chord
 SCF_{empty} = stress concentration factor for empty SHS-SHS T-joint

References

1. S. Berge, On the effect of plate thickness in fatigue of welds, *Eng. Fract. Mech.* **21** (1985) 423-435
2. T. R. Gurney, The influence of thickness on fatigue of welded joints — 10 years on (a review of British work), in *Proc. 8th Int. Conf. Offshore Mech. Arctic Eng.*, The Hague, The Netherlands **3** (1989), pp. 1-8.
3. O. Vosikovskiy, R. Bell, D. J. Burns and U. H. Mohaupt, Thickness effect on fatigue of welded joints-review of the Canadian program, in *Proc. 8th Int. Conf. Offshore Mech. Arctic Eng.*, The Hague, The Netherlands **3** (1989), pp. 9-19.
4. J. de Back, D. R. V. van Delft and C. Noordhoek, The effect of plate thickness on fatigue life of welded tubular joints and flat specimens, in *Proc. 8th Int. Conf. Offshore Mech. and Arctic Eng.*, The Netherlands **3** (1989), pp. 31-37.
5. A. M. van Wingerde, D. R. V. van Delft, J. Wardenier and J. P. Packer, Scale effects on the fatigue behaviour of tubular structures, in *Proc. IIW Int. Conf. Performance Dynam. Loaded Welded Struct.*, San Francisco, USA (1997), pp. 123-135.
6. SAA: *Steel Structures, Australian Standard AS 4100-1998*, Standards Association of Australia, Sydney, Australia (1998).
7. Department of Energy, *Offshore Installations: Guidance on Design, Construction and Certification*, 4th edn. (HMSO, London, UK, 1990).
8. A. Hobbacher, *Fatigue Design of Welded Joints and Components*, Recommendations of IIW Joint Working Group XIII-XV, XIII-1539-96/XV-845-96 (Abington Publishing, Cambridge, England, 1996).

9. A. Schumacher, A. Nussbaumer and M. A. Hirt, Fatigue behaviour of welded CHS bridge joints: Emphasis on the effect of size, *Tubular Structures X*, in *Proc. 10th Int. Symp. Tubular Struct., ISTS10*, Madrid, Spain (2003), pp. 365–374.
10. I. F. C. Smith and T. R. Gurney, Changes in the fatigue life of plates with attachments due to geometrical effects, *Welding Research Supplement*, September issue (1986) pp. 244s–250s.
11. H. Wohlfahrt, T. Nitschke-Pagel and W. Zinn, Improvement of the fatigue strength of welded joints by post-weld treatment methods — A comparison of the results of high strength structural steels and high strength aluminium alloys, *Welding in the World/Soudage dans le Monde* **38** (1996) 307–316.
12. P. J. Haagensen and S. J. Maddox, IIW recommendations on post weld improvement of Steel and Aluminium Structures, IIW Commission XIII, Working Group 2 — Improvement Techniques, XIII-1815-00, Prague, revised (2005).
13. S. Berge and S. E. Webster, The size effect on the fatigue behaviour of welded joints, Paper PS 8, Developments in Marine Technology 3, in *Proc. 3rd Int. Conf. Steel Marine Struct., SIMS'87*, Delft, The Netherlands (1987), pp. 179–203.
14. Y. Xue, J. Xu, H. Li and Y. Li, Influence of plate thickness on fatigue behaviour of welded joints in air and seawater, *China Ocean Eng.*, **4**(2) (1990) 179–188.
15. I. S. Cole, O. Vittori and G. Cerretti, Cathodic protection and thickness effect: A final conclusion?, in *Proc. 3rd Offshore Polar Eng. Conf.*, Singapore (1993), pp. 309–316.
16. *IIW: Fatigue Design Procedures for Welded Hollow Section Joints*, IIW Doc. XIII-1804-99, IIW Doc. XV-1035-99, Recommendations for IIW Subcommittee XV-E, eds. X. L. Zhao and J. A. Packer (Abington Publishing, Cambridge, UK, 2000).
17. X. L. Zhao, S. Herion, J. A. Packer, R. Puthli, G. Sedlacek, J. Wardenier, K. Weynand, A. Wingerde and N. Yeomans, *Design Guide for Circular and Rectangular Hollow Section Joints under Fatigue Loading* (Verlag TUV Rheinland, Koln, Germany, 2000).
18. A. Schumacher, Fatigue behaviour of welded circular hollow section joints in bridges, PhD thesis No. 2727, Department of Civil Engineering, Faculty of Built Environment and Architecture, Ecole Polytechnique Federale De Lausanne, Switzerland (2003).
19. S. Berge, The plate thickness effect in fatigue-predictions and results (a review of Norwegian work), in *Proc. 8th Int. Conf. Offshore Mech. Arctic Eng.*, The Hague, The Netherlands **111** (1989), pp. 21–30.
20. O. Örsjasaeter, A. Drågen, P. J. Haagensen, B. Lian and Å. Gunleiksrud, Effect of plate thickness on the fatigue properties of low carbon-micro-alloyed steel, Paper TS 6, Developments in Marine Technology 3, in *Proc. 3rd Int. Conf. Steel Marine Struct., SIMS'87*, Delft, The Netherlands (1987), pp. 315–335.
21. W. Weibull, Zur Abhängigkeit der Festigkeit von der Probengröße, *Ingenieur Archiv*, **28** (1959) 360–362.
22. G. Savaidis, A. Savaidis, G. Tsamasphyros and Ch. Zhang, On size and technological effects in fatigue and prediction of engineering materials and components, *Int. J. Mech. Sci.* **44** (2002) 521–543.
23. J. L. Overbeeke and H. Wildschut, The influence of plate thickness on the endurance of welded joints, Paper TS 1, Developments in Marine Technology 3, in *Proc. 3rd Int. Conf. Steel Marine Struct., SIMS'87*, Delft, The Netherlands (1987), pp. 247–257.
24. S. Walbridge, A. Nussbaumer and M. A. Hirt, Fatigue behaviour of improved tubular bridge joints, in *10th Int. Symp. Tubular Struct.*, Madrid (2003).
25. C. E. Phillips and R. B. Heywood, The size effect in fatigue of plain and notched specimens loaded under reversed direct stress, *Proc. Inst. Mech. Eng.* **165** (1951) 113–124.
26. T. R. Gurney, Theoretical analysis of the influence of toe defects on the fatigue strength of fillet welded joints, Welding Institute Research Report 32/1977/E (1977).

27. T. R. Gurney, The influence of thickness on the fatigue strength of welded joints, Paper 41, in *Proc. 2nd Int. Conf. Behaviour Offshore Struct.*, BOSS'79, London, England (1979), pp. 523–534.
28. U. H. Mohaupt, D. J. Burns, J. G. Kalbfleisch, O. Vosikovskiy and R. Bell, Fatigue crack development, thickness and corrosion effects in welded plate to plate joints, Paper TS 3, Developments in Marine Technology 3, in *Proc. 3rd Int. Conf. Steel Marine Struct., SIMS'87*, Delft, The Netherlands (1987), pp. 269–280.
29. G. S. Booth, The effect of thickness on the fatigue strength of plate welded joints, Paper TS 2, Developments in Marine Technology 3, in *Proc. 3rd Int. Conf. Steel Marine Struct., SIMS'87*, Delft, The Netherlands (1987), pp. 259–268.
30. S. Berge, O. I. Eide, O. C. Astrup, S. Palm, S. Wastberg, A. Gunleiksrud and B. Lian, Effect of plate thickness in fatigue of welded joints in air and in seawater, Paper TS 45, Developments in Marine Technology 3, in *Proc. 3rd Int. Conf. Steel Marine Struct., SIMS'87*, Delft, The Netherlands (1987), pp. 799–810.
31. C. Noordhoek, D. R. V. van Delft and A. Verheul, The influence of plate thicknesses on the fatigue behaviour of welded plates up to 160 mm with an attachment or butt weld, Paper TS 4, Developments in Marine Technology 3, in *Proc. 3rd Int. Conf. Steel Marine Struct., SIMS'87*, Delft, The Netherlands (1987), pp. 281–301.
32. O. I. Eide and S. Berge, Fatigue of large scale plate girders with plate thicknesses 20, 40 and 60 mm, Paper TS 7, Developments in Marine Technology 3, in *Proc. 3rd Int. Conf. Steel Marine Struct., SIMS'87*, Delft, The Netherlands (1987), pp. 337–347.
33. D. R. V. van Delft, C. Noordhoek and J. de Back, Evaluation of the European fatigue test data on large size welded tubular joints for offshore structures, in *Proc. 17th Ann. Offshore Tech. Conf.*, Houston, Texas, OTC 4999 (1985), pp. 351–356.
34. IIW: Recommendations for fatigue design of welded joints and components, IIW Doc. XIII-1965-03/XV-1127-03, IIW Joints Working Group XIII-XV, IIW Annual Assembly, Prague (2005).
35. BSI, Fatigue design and assessment of steel structures, BS7608, British Standards Institution, London, UK (1993).
36. EC3, Eurocode 3: Design of Steel Structures—Part 1.9, Fatigue, European Committee for Standardisation (2003).
37. G. J. van der Vegte, Low cycle fatigue of welded structures—Part C: Tubular T- and X-joints, Report Stevin Laboratory, Delft University of Technology, The Netherlands (1998).
38. G. J. Hancock, Recent research and design developments in cold-formed open section and tubular members, in *Proc. 2nd Int. Conf. Adv. Steel Struct., ICASS'99*, Hong Kong 1 (1999), pp. 25–37.
39. ASTM: *Standard Specification for Cold-Formed Welded and Seamless Carbon Steel Structural Tubing in Rounds and Shapes—Specification A500-01*, American Society for Testing and Materials, West Conshohocken, PA, USA (2001).
40. SAA: *Structural Steel Hollow Sections*, Australian Standard AS1163-1991, Standards Association of Australia, Sydney, Australia (1991).
41. CEN: Cold formed welded structural hollow sections of non-alloy and fine grain steels—Part 2: Tolerances, dimensions and sectional properties, EN10219-2: 1997, Committee for European Standardization, Brussels (1997).
42. STI: *Hollow Structural Sections—Principal Producers and Capabilities*, Steel Tube Institute of North America, Mentor, Ohio, USA (2001).
43. F. R. Mashiri, X. L. Zhao, P. Grundy and L. Tong, Fatigue design of very thin-walled SHS-to-plate joints under in-plane bending, *Thin-Walled Struct.* **40**(2) (2002) 125–151.

44. F. R. Mashiri, X. L. Zhao and P. Grundy, Fatigue tests and design of thin cold-formed square hollow section-to-plate T-connections under in-plane bending, *J. Struct. Eng., ASCE* **128**(1) (2002) 22–31.
45. F. R. Mashiri, X. L. Zhao and P. Grundy, Fatigue tests and design of welded T-connections in thin cold-formed square hollow sections under in-plane bending, *J. Struct. Eng., ASCE* **128**(11) (2002) 1413–1422.
46. F. R. Mashiri and X. L. Zhao, Effect of thickness and joint type on fatigue performance of welded thin-walled tube-plate T-joints, in *Proc. 1st Int. Conf. Adv. Exp. Struct. Eng. (AESE, 2005)*, Nagoya, Japan (2005), pp. 877–884.
47. X. L. Zhao and G. J. Hancock, Butt welds and transverse fillet welds in thin cold-formed RHS members, *J. Struct. Eng. ASCE* **121**(11) (1995) 1674–1682.
48. F. R. Mashiri, X. L. Zhao and P. Grundy, Fatigue behaviour of thin-walled tube-tube T-joints under in-plane bending, *Tubular Structures IX*, in *Proc 9th Int. Symp. Euroconf. Tubular Struct.*, Düsseldorf, Germany, **ISTS9** (2001), pp. 259–268.
49. C. Noordhoek, J. Wardenier and D. Dutta, The fatigue behaviour of welded joints in square hollow sections—Part 2: Analysis, Stevin Report 6-80-4, TNO-IBBC Report BI-80-10/0063.4.3821, Department of Civil Engineering, Delft University of Technology, Delft, The Netherlands (1980).
50. F. R. Mashiri, X. L. Zhao and P. Grundy, Effects of weld undercut on the fatigue life of welded connections in thin-walled structures, in *Proc. Struct. Integrity Fracture*, Australian Fracture Group Inc., Melbourne, Australia (1998), pp. 81–91.
51. F. R. Mashiri, X. L. Zhao and P. Grundy, Effect of weld profile and undercut on fatigue crack propagation life of thin-walled cruciform joint, *Thin-Walled Struct.* **39**(3) (2001) 261–285.
52. F. R. Mashiri and X. L. Zhao, Fatigue behaviour of welded composite tubular T-joints under in-plane bending, *Thin-Walled Struct. — Adv. Res. Des. Manufactur.*, in *Proc. 4th Int. Conf. Thin-Walled Struct.*, Loughborough, United Kingdom, **ICTWS4** (2004), pp. 491–498.
53. F. R. Mashiri and X. L. Zhao, Effect of thickness and joint type on fatigue performance of welded thin-walled tube-tube T-joints, tubular structure XI, in *Proc. 11th Int. Symp. IIW Int. Conf. Tubular Struct., ISTS11*, Quebec City, Canada (2006), pp. 87–95.